

# A Laboratory Experiment for Testing Space-Time Isotropy

Stoyan Sarg Sargoytchev

Department of Computer Science and Engineering, York University, Toronto, Canada

E-mail: sto.sarg@gmail.com

The anisotropy of the Cosmic Microwave Background Radiation invokes the idea of using a new method for testing the space-time isotropy in a laboratory. It also raises a question about a possible dependence of the speed of light isotropy on the gravity dependence on altitude. Presently, the operational management of the GPS system applies corrections indicating the existence of a universal clock. This does not fully comply with the definition of the inertial frame according to Special Relativity. In the original Michelson-Morley experiment and some later experiments, the expected “ether drag” was not confirmed but a small non-null effect was detected. Dayton Miller and Yu .M. Galaev found that the observed non-null effect is greater at a higher altitude. The second order experiments based on interferometric methods may not be able to isolate the origin of this effect because of the ambiguity between the Doppler shift and the relativistic clock rate change. The methodology in the suggested new experiment is expected to put a new light on the enigmatic non-null effect. It is based on measurement of the ratio between refractive indices of two different optical media by using a collimated beam that obtains different orientations in respect to the CMB anisotropy during the sidereal and orbital motion of the Earth.

Keywords: CMB anisotropy, ether drift non-null results, time noise

## 1. Introduction.

After the Cosmic Microwave Background (CMB) radiation was initially predicted by G. Gamow, R. Alpher and R. Herman and later by R. Dicke (1960), it was experimentally discovered by Arno Penzias and Robert Wilson in 1965. In 1978, Penzias and Wilson were awarded the Nobel Prize for Physics. In 1966 T. F. Howel and J. R. Shakeshaft were able to distinguish the CMB blackbody radiation from a non-blackbody radiation coming from our galaxy while analyzing the data from a broader microwave spectral range [1]. In 1967 D. T Wilkinson and R. B. Partridge published an article about the anisotropy observed in the spatial distribution of quasi-stellar objects [2]. In 1967, J. M. Stewart and D. W. Sciama predicted anisotropy in microwave radiation and described a method for detection of solar system motion in respect to distant matter [3]. In 1969, E. K. Conklin published an article “Velocity of the Earth with Respect to the Cosmic Background Radiation” [4]. Using the method described in [3] and data from 23 observations with a radiometer operated at 8 GHz and bandwidth of 1.2 GHz, he obtained a velocity vector with magnitudes of 160 km/s towards RA 13 hrs and declination of  $32^{\circ}$ . The detected motion he claimed is a result of two combined motions: the solar system rotation in the Milky Way and the solar motion in respect to the local supercluster of galaxies. After the launch of the Cosmic Background Explorer (COBE) in 1989, the CMB anisotropy was accurately determined by George Smoot [5]. In 2006, he was awarded a Nobel Prize for his work. From a later WMAP experiment, C.L. Bennett et al. confirmed the results of CMB anisotropy with improved accuracy: a spatial dipole anisotropy of 0.123% towards  $l = 263.85^{\circ}$   $b = 48.25^{\circ}$  in a galactic coordinate system [6.] B. Nodland and J. P. Ralston, while investigating the polarized radiation emitted by distant radiogalaxies, also found a signature of anisotropy in electromagnetic propagation over cosmological distances [7].

The existence of CMB anisotropy raises the following questions: (1) Is this a spatial anisotropy or an anisotropy of the speed of light; (2) Is the anisotropy detectable within the Earth gravitational field? The answers to these questions are important. On one hand, they are related to Einstein’s theory of Special Relativity and on the other to the cosmological model of the Universe. Some unexplained effects known as “non-null” results from the old and new “ether-drift” (light-speed anisotropy) experiments must also be taken into account. The directions of detected “non-null”

results usually do not agree with the direction of CMB anisotropy and they are spread in a wide spatial angle. The problem in some cases might be an improperly selected experimental method as discussed hereafter.

Attempts to detect a possible light speed anisotropy has a century long history. In 1887 Michelson and Morley reported the results from their famous experiment [8]. The expected drag effect from a Luminiferous Ether was not confirmed, but a small non-null effect was observed. One of the most prominent researchers of the non-null effect was David Miller. He first observed the dependence of this effect on altitude [9]. In 1929 Michelson repeated his experiment in the basement of the Wilson Mount observatory and obtained the same result with the unexplainable non-null effect [10]. In 1927 E. Esclançon, director of the Paris Observatory, published results from his year-long experiment conducted in the Observatory of Strasburg at an altitude of 142 m [11]. He also detected a non-null effect at the same right ascension as Miller. After Miller, a few experiments have been done in the past century with different results [12]. The experiments of R. J. Kennedy [13] and K. K. Illingworth [14] are often cited in refutations of the Miller result, but a careful analysis of their experiments based on the Kennedy method reveals one problem. They used a monochromatic light from a 546.1 Hg arc lamp collimated by a lens along an axis lying in the horizontal plane. In such an arrangement, the emitted light at the source has a spatial orientation and it is subject to a small wavelength change depending on direction. This may cancel the detection of the non-null effect, because according to the Lorentz theorem (1899) the frequency of the oscillating electrons generating the light waves is lower in systems in motion than in those at rest by:

$$\gamma T = T / \sqrt{1 - V^2/c^2} \quad (1)$$

Miller, like Michelson, used white light. Miller mentioned explicitly that a light from a small acetylene lamp in a stationary arrangement was “brought to the interferometer in the axis of rotation” (p. 220) [9]. In such an arrangement, the emission is not dependent on the direction of instrument rotation. Esclançon also used white light. Nobody after Michelson, Miller and Esclançon used a white light source.

After 1980 a number of other ether-drift experiments were able to measure a non-null effect [15,16,17,19,20,21,22,23,24]. In a recently published article (2007), C. E. Navia et al. reviewed and analyzed the results from the light speed anisotropy experiments and the CMB anisotropy. They suggested that the problem might be in the theoretical treatment of Lorentz-Poincaré and Einstein’s Special theory of Relativity, because they do not involve gravitation [20]. Navia et al. used a new method for investigating light speed anisotropy proposed by C. M G. Lattes based on diffraction, but the derived direction differed from the direction reported by other researchers. In this respect, it is worth mentioning the articles of Red Cahill [21]. He provided a light anisotropy experiment based on a time measurement in two counter-propagated signals – one in optical fiber and another in coaxial cable [21]. While he could not offer a physical explanation why this method is able to detect anisotropy, he concluded that only the signal in coaxial cable is affected. A better explanation of this and discussion of his results will be provided hereafter.

David Miller devoted more than 30 years to investigating the speed of light anisotropy before delivering the final results. These have since been confirmed by a number of modern experiments. In 1933 Miller published his experimental work in an extensive paper published in the Review of Modern Physics [9]. In the International Congress of Physics in Paris 1900, Lord Kelvin strongly urged the repetition of the Michelson-Morley experiment in order to test the Lorentz-Fitzgerald hypothesis. Morley and Miller then constructed a new interferometer with longer arms. From 1902 it was tested initially with a wooden frame. In 1904, with funding from the American Academy of Art and Sciences, a new instrument with a steel cross frame was built. In order to increase the optical path for higher sensitivity, each of the two 90 degree arms had 8 mirrors (4 mirrors at each end). In such an arrangement, the effective length of the arm was 3203 cm and the total path of the going and

returning beam was 6406 cm. The instrument weighed about 1200 kg and floated on 275 kg of mercury. In 1921 the steel cross frame was replaced with a base of concrete. The instrument was tested with monochromatic and white light sources but all the measurements were made with a white (broad band) light source. The fringes were observed with a small telescope while the instrument was in slow continuous rotation. In 1905 the instrument was temporarily mounted at Cleveland Heights at an altitude of about 285 m where some measurements were made. In 1921 the instrument was mounted at the Mount Wilson Observatory at an altitude of about 1750 m where extensive observational data were accumulated for a few years.

One unexplainable effect mentioned by Miller and also previously observed by Michelson - Morley is a systematic small non-null result he called “a reduced velocity”, because it matches the direction of the Earth motion but not the real velocity. Miller found that this non-null effect is greater at higher altitudes. In Cleveland, which is at 265 m above sea level, Miller observed a reduced velocity of about 3 km/s, while at Mount Wilson (1750 m above sea level) it was about 10 km/s. Also, it varied from 9.3 km/s in February to 11.2 km/s in August. To verify the altitude dependence of this effect, Miller returned the heavy instrument to the laboratory at Cleveland in 1922 and 1923 where he did many trials for identifying possible side effects, and then reestablished it back at Wilson Height in 1925 – 1926. The fringe shift caused by a possible speed-of-light anisotropy will have 3 components: from the sidereal Earth rotation, from the orbital rotation and from the solar system motion. The fringe shift from the sidereal rotation of the Earth should not be expected to be symmetrical because the cosine between the beam axis and the vector of the solar system velocity varies around some constant angle. Then the combination of all these effects may cause a diurnal distortion of the 24 hrs fringe shift cycle. Some additional fluctuations of the 24 hr cycle were observed not only by Dayton Miller but also in many other experiments. Their possible cause will be discussed later in the discussion section of this article. Despite all these distortions, the final analysis of all refined data that Miller collected from 1924 to 1926 revealed that the Earth with the solar system is moving with a velocity of about 208 km/s towards the apex having a right ascension of 4 hrs and 54 minutes and declination of -70 Deg 33’ (for the epoch of 1924). He found that the orbital component of the Earth motion was difficult to detect in a short period because it is almost perpendicular to the velocity vector of the solar system motion. In 1929 A. A. Michelson, F. G. Pease and F. Pearson repeated the experiment in the basement of Mount Wilson Laboratory. The non-null effect is stated in their article published in Nature, where they say: “The results gave no displacement as great as one-fifteenth of that to be expected on the supposition of an effect due to a motion of the solar system of three hundred kilometers per second” [10].

While only Miller investigated the dependence of the non-null effect on altitude during the past century, some recent experiments at different heights were performed in Russia and the Ukraine. In 2001 and 2002 Yu. M Galaev published articles describing experiments sponsored by the Institute of Radiophysics and Electronics of NSA, Ukraine [14,15]. The Galaev experiments are based on original two-way interferometers, one in the optical band and another in the millimeter radiowave band. The measurements in the optical band were performed at heights of 1.6 m and 4.75 m above sea level from August 2001 to January 2002. With the radiowave interferometer, the measurements were at an altitude of 1414 m above sea level from September 1998 to January 1999. Galaev compared the results from these two experiments with Miller’s results and they matched closely. The log-log plot of the observed non-null effect at different heights from the three experiments appears linear. It is shown in Fig. 1.

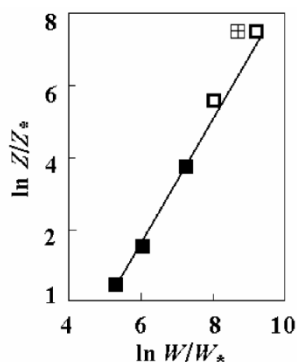

The measurements were at an altitude of 1414 m above sea level from September 1998 to January 1999. Galaev compared the results from these two experiments with Miller’s results and they matched closely. The log-log plot of the observed non-null effect at different heights from the three experiments appears linear. It is shown in Fig. 1.

Fig. 1 Dependence of the ether-drift velocity (non-null effect) on altitude at five different heights above sea level (1.6 m, 4.45 m, 42 m, 265 m and 1830 m). The black squares are from Galaev’s experiments [17,18], the white squares are from Michelson’s [8,10] and Dayton Miller’s [9] experiments. Courtesy of Galaev [18].

The non-null effect and its dependence on altitude is an interesting phenomenon from the point of view of Special Relativity (SR). On one hand, it's small value confirms the validity of SR in the strong Earth gravitational field with some degree of accuracy, but on the other hand, it indicates that some correction might be needed at higher altitudes. This conclusion is supported by the fact that the operational management of the GPS system requires clock corrections that do not fully comply with SR. This is discussed in a number of articles published by Ronald Hatch, a pioneer in the GPS system [22,23]. The GPS satellites are at an altitude of about 20,000 km from the ground and the correction is quite above the statistical error. This indicates the existence of universal time, something that does not comply with the SR definition of inertial frame. This problem is discussed also in the article of Wang and Hatch [24] and the concluding comments of Cynthia Whitney's article [25]. Hatch also believes that the clock depends on the gravitational potential and suggests that a Mossbauer experiment be performed in free fall conditions [26]. The clock rate behavior of Soviet satellites and missions is discussed by V. H. Hoteev in his monographs "Discussion about the Universe" [36]. S. K. Whitney provides a good methodological classification of different types of ether drift experiments. It shows also that the light velocity anisotropy may provide different signatures in first and second order experiments (in respect to  $V/c$  ratio) [25].

The linear plot of the non-null effect shown in Fig. 1 deserves careful analysis. It is known that the air refractive index is slightly dependent on altitude but this dependence is not linear. As well, the gravitational potential is inversely dependent on altitude. One might expect that SR may need some correction due to the altitude dependence of gravity or the refractive index of air.

Some recent experiments also detected a light propagation anisotropy. Amongst them are the experiments based on rotated active cryogenic optical resonators [19], the diffraction experiment of Navia et al. [20] and the experiment of R. T. Cahill reported in 2006 [21]. Amongst the different experiments, only the Miller, Galaev and Cahil experiments provide a close match between derived spatial directions. An important issue in these experiments is that sidereal rather than diurnal time was used in data processing. It is an indication that the light-speed anisotropy is not related to Earth-orbital motion but to the solar system motion in some absolute frame of reference. According to Cahill "absolute motion is motion presumably relative to some substructure to space, whereas Lorentz transformation Lorentz symmetry parameterizes dynamical effects caused by the motion of systems through that substructure" [21]. In 2002 S. Sarg suggested a model of a superfine substructure that provides space-time properties and physical explanations of Special and General relativistic effects in absolute space [27,28].

## 2. A methodological problem leading to ambiguity

The space-time property of the physical vacuum is one of the important consequences of Einstein's theory of relativity. From the equation  $c = \lambda \nu$  we see that wavelength is directly defined by frequency when the speed of light  $c = const$ . However, if assuming anisotropy of the speed of light, the data interpretation suffers from ambiguity - we cannot determine which of the three parameters is actually affected. This is valid for all experiments using interferometric principles and confuses the data interpretation. This might be the reason for the wide spread of directions of light propagation anisotropy detected by different experiments.

The one and two-way optical experiments described in the literature are usually based on the interferometric principle. The two-way interferometric experiments are either with two channels at 90 deg such as in the Michelson-Morley experiment or with two opposite channels. They could not eliminate ambiguity from the relativistic clock rate change and the wavelength change caused by the Earth motion. Navia et al. provided an experiment based on the use of a diffraction grating, as proposed by C. M G. Lattes, but it also is not free from ambiguity [20]. In the method description of their experiment, they made the assumption that the frequency in the relation  $\lambda = c/\nu$  is constant,

but it could not be if considering a clock rate change. The one-way experiments based on the Mossbauer effect are very accurate, but they also could not eliminate the above-mentioned ambiguity.

Let us take, for example, the classical Michelson-Morley type of experiment with two arms at 90 deg. The path difference between both arms is adjusted to be close to zero. The interferometer is slowly rotated and measurements are taken at different angular positions of the arms in respect to the North-South direction. Let us consider that the maximum fringe shift (or number of fringes) corresponding to the non-null effect is between two angular positions distinguished by 90 degrees. If the path difference is adjusted to zero in one of these positions, the fringe shift at the other 90 deg position must be contributed by a small change of the path difference between the two arms. Presently, interferometers with non-zero path difference are successfully used for measurement of wind velocity [29,30] and their theory is well established. The change of wind velocity  $\partial V$  corresponds to a fringe shift  $\delta\phi$  according to the expression.

$$\delta\phi = 2\pi \frac{\Delta}{\lambda} \frac{\partial V}{c} \quad (2)$$

where:  $\Delta = Ln$  - is the path difference,  $n$  - a refractive index of the involved optical media,  $L$  - path length,  $\lambda$  - wavelength for monochromatic source (or effective wavelength for white source - 570 nm in Miller's experiments) contributed to the fringes,  $c$  - speed of light

According to the Einstein definition of inertial frame, the Earth motion should not affect the local speed of light, so the air refractive index should not be affected. Then the refractive index of glass will only participate in equation (2), for which we have  $n = c/c_G$ , where  $c$  - is the speed of light in air and  $c_G$  - the speed of light in the glass. Substituting this in (1) and rearranging we obtain

$$\delta\phi = 2\pi \frac{L}{\lambda} \frac{\partial V}{c_G} \quad (3)$$

Let us analyze (3) to find out what parameter change may contribute to the small fringe shift corresponding to the non-null effect.  $L$  and  $\lambda$  are of the same dimensions (length), but  $\lambda$  could be affected by the clock rate change or by a Fitzgerald contraction, while  $L$  - only by a Fitzgerald effect, in other words - by some space-time effect. However, the ratio  $L/\lambda$  is dimensionless, so it could not be affected by such a space-time effect. Assuming the validity of the Einstein postulate mentioned above, one could not expect a change in  $\partial V$ . Then the only parameter to be affected is the speed of light in glass  $c_G$  that may change a small amount. The conclusion is that the small fringe shift (non-null effect) should be caused by some small change in the ratio between the refractive indices of glass and air. This effect could be measured by a non-interferometric method in which the ambiguity from the possible clock rate change, Doppler shift and Fitzgerald contraction is eliminated in the determination of the direction of the anisotropy. The obtained direction could be compared to the anisotropy of the Cosmic Microwave Background.

The wavelength  $\lambda$  in Equation (3) is for the propagated light, not for the source. Only Michelson and Miller used a white light that was isotropically emitted from the source. All later interferometric experiments used a monochromatic source including lasers, which are usually anisotropically emitted and may cancel the non-null effect. This could be one of the reasons that some later experiments did not detect a non-null effect.

Our initial choice for a non-interferometric experiment was an attempt to replicate the coupled shutters experiment of S. Marinov reported after his death by one of his collaborators [31]. The experiment is based on signal intensity measurements in two counter-propagated beams with high-speed kinematics. This experiment was carefully tested at York University, Toronto, but the conclusion was that a number of technical problems made this experiment not feasible for achieving

the needed accuracy [32]. However, the extensive testing of different modifications led to the idea of a new method that was implemented in the experiment discussed hereafter.

### 3. Technical method and description of the proposed experiment

The ambiguity from the relativistic clock rate and wavelength change could possibly be eliminated if the method is based on measuring the ratio between the refractive indices of two optical media with different refractive indices. The effect of wavelength change could be strongly suppressed by using a broadband optical source and detectors. To detect only the refractive index change we will use two dissimilar arms. In one of the arms, an array of consecutive parallel glass windows with air gaps between them must be used. They must be tilted at the proper angle with respect to the collimated beam. Due to the multiple reflections from the entrance and exit glass surfaces, the output beam will be attenuated and slightly displaced. Let us assume that the refractive index ratio slightly depends on the angle between the optical beam axis and the light propagation anisotropy. Then with a change of this angle, the rays of the passing beam will undergo a slight parallel shift. If the beam is focused by a lens possessing a spherical aberration, the parallel ray shift will cause a slight image change. This change could be detected if a proper slit is put in front of the detector.

The Fresnel reflectance and transmittance from a flat optical surface for near normal incidence are given by the expressions (4). They are valid for the entrance and exit surfaces of a flat window without a coating.

$$R = \left( \frac{n_2 - n_1}{n_2 + n_1} \right)^2; \quad T = 1 - R \quad (4)$$

where: R – reflectance, T – transmittance,  $n_1$  and  $n_2$  refractive indices of the glass and air

For a tilted surface with a beam incidence angle  $\theta_1$  the refracted angle  $\theta_2$  is given by

$$\cos \theta_2 = \left[ 1 - \left( \frac{n_1}{n_2} \right)^2 \sin^2 \theta_1 \right]^{1/2} \quad (5)$$

If the tilting approaches the Brewster angle given by Eq. (6) a partial polarization occurs.

$$\theta_B = \arctan \left( \frac{n_2}{n_1} \right) \quad (6)$$

For a flat window in air, we have  $n_1 = 1.000226$ . For BK7 glass in a spectral range between 404 nm and 852 nm the mean refractive index is 1.516, so the Brewster angle is  $56.6^\circ$ . For incidence angle smaller than the Brewster angle, Equations (3) and (4) are valid. When considering multiple reflections and transmissions in an array of a finite number of parallel windows, the total integral transmission will approach 50% for a proper incidence angle below the Brewster angle. This could be achieved by an array of 12 windows if using uncoated windows of BK7 glass and tilting angle of about  $40^\circ$ . From Equations (4), (5) and (6) one may see that the passing beam will exhibit a change only if the ratio ( $n_2/n_1$ ) changes. Detection of such a change due to the diurnal and orbital motion of the Earth will indicate a light velocity (or space-time) anisotropy. The possible gravitational influence from the Moon could also be detected.

The optical layout of the proposed experiment is shown in Figure 2.

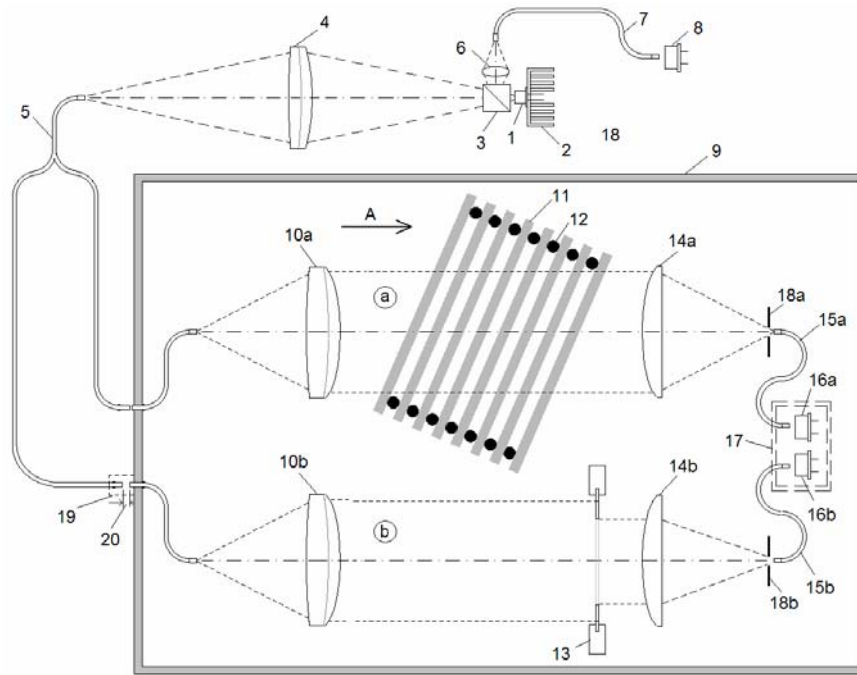

Fig. 2. Optical layout of the experiment.

The broadband light source 1 is a white InGaN LED with a Ce:YAG phosphor manufactured by TopBright, HongKong. It has an intensity of 35 candella and a spectral range from 450 to 750 nm with a maximum peak at 465 nm from InGaN LED and a broad secondary maximum at 550 nm from Ce:YAG. The LED source emits within an angle of  $\pm 10^\circ$ . The light passing through a beam splitter 3 is focused by the lens 4 to the fiber optics guide 5 splitting into two ends – one for the measurement channel (a) and another one for the reference channel (b). The beams for each channel are collimated by achromatic lenses 10a and 10b with EFL of 10 cm. The collimated beam for channel (a) passes through a set of 13 uncoated flat windows with thickness of 2 mm and gaps of 2 mm. The windows are tilted at an angle of  $36^\circ$  in respect to the beam axis. The reference channel (b) has an adjustable iris diaphragm 13 for adjusting the intensity of the reference beam to be similar to the measuring one. The plano-convex lenses 14a and 14b with EFL of 10 cm focus the beams into fiberoptics guides 15a and 15b in front of which are mounted circular diaphragms 18a and 18b with a diameter of 1 mm. The lenses 14a and 14b are intentionally selected to be non-achromatic and non-aplanatic. The ends of 15a and 15b guide the lights from both channels to the silicon photodiodes 16a and 16b mounted on a common plate. The photodiodes are ODD-12W from Opto Diode Corp. with a circular sensitive area of 4mm diameter. In order to prevent any influence from ambient change of pressure and humidity, both optical channels with the photodiodes must be enclosed in a housing 9 at normal air pressure. For facilitating the optical adjustment, an additional fine adjustment of the beam intensity of the reference channel is possible by tuning the gap 20 between the two fiberoptics ends. The air in the gap should also be sealed by using O-rings. The current through the white LED source is stabilized at 25 mA. Additionally, the source could be optically stabilized. For this reason an additional optical channel can be used comprised of a beam splitter 3, a lens 4, a fiber optics guide 5 and a photodiode 8. The photodiode must be of the same type as 16a and 16b. The optical elements and photodetectors of the measuring and reference channels are mounted on a small optical table with dimensions 70 cm x 35 cm.

During the measurements, the LED source is periodically turned ON and OFF for a time much longer than the time constant of the amplifiers. This is for monitoring a possible drift due to the photodiode dark current or amplifiers gain. In case of a more powerful LED source, the radiator

could be thermally stabilized and the LED should be always ON while the ON/OFF switching can be done by a shutter. The optical channels' axes are oriented in the North-South direction. The sidereal rotation of the Earth causes a change of the angle between the beam axis and the larger velocity component of the Earth motion. If anisotropy in light propagation exists, the effect will be a slight parallel shift of the beam rays in channel (a) after passing through the parallel windows 11. This effect is based on the assumption that the anisotropy will cause a slight change of the ratio between the refractive index of the air and the BK7 glass. The plano-convex lens 14a has a larger aberration for non-central rays, so in contrast to the achromatic lens, it focuses a parallel light not into a sharp spot but into a comma image. The axial beam displacement will cause a comma increase that could affect the light passing through the diaphragm 18a. With a properly selected tilt angle of the parallel windows and the position of the diaphragm 18a coupled to the fiber optics guide 15a, the necessary sensitivity could be achieved.

For measurement of the difference between channels (a) and (b), the circuit diagram of the amplifier unit is shown in Fig 3. It also includes two additional amplifier stages for measuring the signal in each channel.

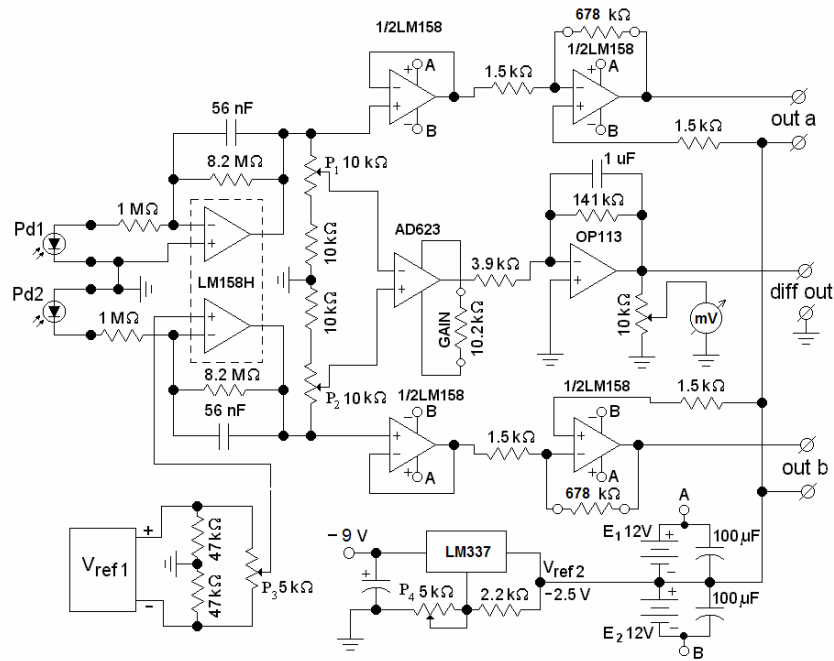

Fig. 3. Circuit diagram of the amplifier unit

The photodiodes 16a and 16b operate in a photovoltaic mode. They are connected through resistors of 1 MΩ to the inverted inputs of two operational amplifiers in a common package LM158H. This provides a possibility for fine adjustment of the offset caused by the small bias voltage difference between the photodiodes due to the slight difference in their internal shunt resistors. For this purpose a precision voltage reference  $V_{ref1}$  is used with isolated ground. The fine bias adjustment is provided by the multi-turn precision potentiometer  $P_3$ . The precision multi-turn potentiometer  $P_1$  and  $P_2$  at the outputs of LM158 amplifiers serve for fine adjustment in the signal difference from both channels. The following differential amplifier AD623 and the final amplifier OP113 amplify the signal difference until reaching the necessary level for data recording. The gain of AD623 amplifier is adjusted by an external resistor. For suppressing the fluctuations from the photon shot noise and the dark current fluctuations, low pass filtering is used at LM158 and OP113. The output labeled “diff out” is conveyed to a data acquisition system. The supplied voltages of the operational amplifiers are not shown for simplicity. In order to monitor the signal change in the separate channels (a) and (b), two additional amplifier stages are also built based on the LM158



operational amplifiers. They provide output signals at “out a” and “out b” terminals that are not referenced to ground but to a reference voltage about -2.5 V in order to get into a specified voltage range of the differential channels of the data acquisition system. The reference voltage provided by the precision voltage regulator LM337 depends on the signal value, so it is adjustable by potentiometer P4. The two amplifier stages are supplied by separate supply voltages +12 V and -12 V galvanically isolated from the ground of the differential channel. For achieving the necessary accuracy, the gain of all amplifiers must be very stable. For this reason resistor network packages with a low resistance temperature coefficient are used. The separate resistors from the resistor network packages are used for dividers defining the gain of the differential and other two channels so temperature drifts can be compensated.

The fine tuning of the signals from channels (a) and (b) is provided by the precision potentiometers P1 and P2 when the LED source is ON. These adjustments must be made consecutively, with the bias adjusted by the potentiometer P3 when the LED source is off. A millivoltmeter with the needle at the middle scale is helpful for the fine adjustment. The output terminals “diff out”, “out a” and “out b” are connected to a Data Acquisition system (DAQ). For this purpose, an USB DAQ model DI-158U Series from DATAQ Instruments was used. It contains 4 differential analog channels with adjustable gain from 1 to 8 and 12 bit A/D conversion. If a later version DI-158UP with a higher adjustable gain is used, the two amplifier stages for “out a” and “out b” signals and the isolated power supplies +12V and -12 V will not be needed. Only a proper precision reference voltage will be needed in this case.

Fig. 4 shows the experimental setup without a hermetical housing and the front panel of the amplifier unit. The optical channels with the photodetectors are mounted on a small optical table 70 cm x 35 cm, while the white LED source is mounted on the top.

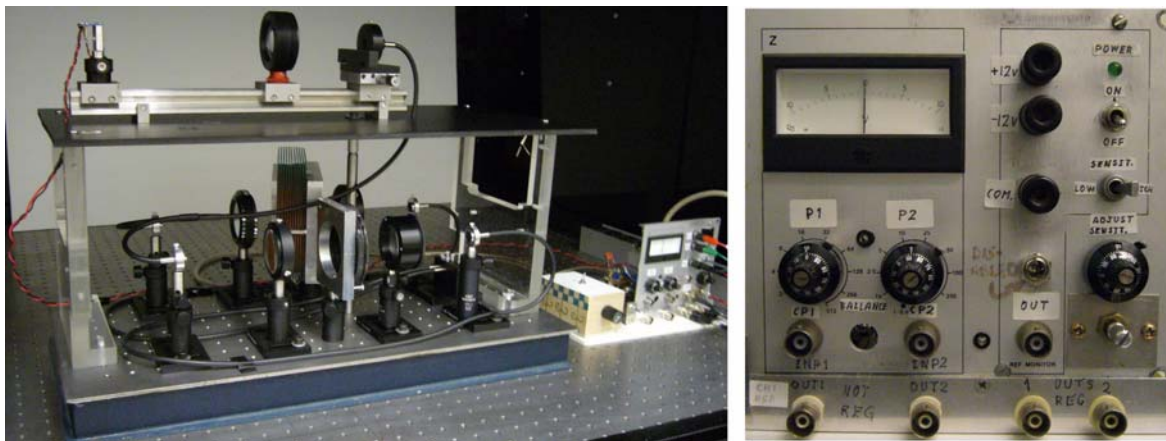

Fig. 4 Optical setup (left) and amplifier unit (right)

#### 4. First results and discussions

The described experiment was setup in April 2010 in one of the basement laboratories at York University, Toronto, at geographical coordinates of 43° 43' N and 79° 20' W and 133 m above sea level. The experiment was built after an extensive test of the coupled shutters experiment reported in [32]. In the initial setup the experiment was not in a sealed enclosure but the humidity, the barometric pressure and ambient temperature were permanently monitored and recorded. Initially the optical channel orientation A (see Fig. 2) was S-N with the intention to test the opposite orientation later, but the latter case was not done since the laboratory was moved. In April and May, the optical and amplifier unit setup was optimized and the tuning procedure was elaborated. More systematic measurements were made in June. The light source LED was stabilized by current at 25

mA and it was periodically turned on/off with ON and OFF duration of 30 min. The data collecting with WINDAQ software from DATAQ Instruments covered periods of about 24 hours but the measurements on some days were stopped, given that there was no prior knowledge of the dynamical range for a long time observation. The reason for this is that the effect from a 24 hr signal appears superimposed on another effect probably dependent on the position of the Moon that is a kind of gravitational effect. The use of a DC shifted reference voltage permitted the amplification for the two single channels to be set to the same level as the differential channel, but the signals “out a” and “out b” appear in the range of the DAQ only when the light source LED is ON. The simultaneous measurement of the differential output and the outputs from the two separate channels was useful for observing that the change in the differential output was caused by the change in the measurement channel (a). The signal from the differential output was adjusted to be in the DAQ range for the ON and OFF states of the light source. This allowed monitoring of the DC drift from the amplifiers. At a proper light level, this drift was significantly suppressed. At the same time, the light intensity was selected to not exceed some level because the photoelectric mode of the photodiode has an upper range non-linearity.

Fig. 5 shows the first measurement results from June 10 to June 13.

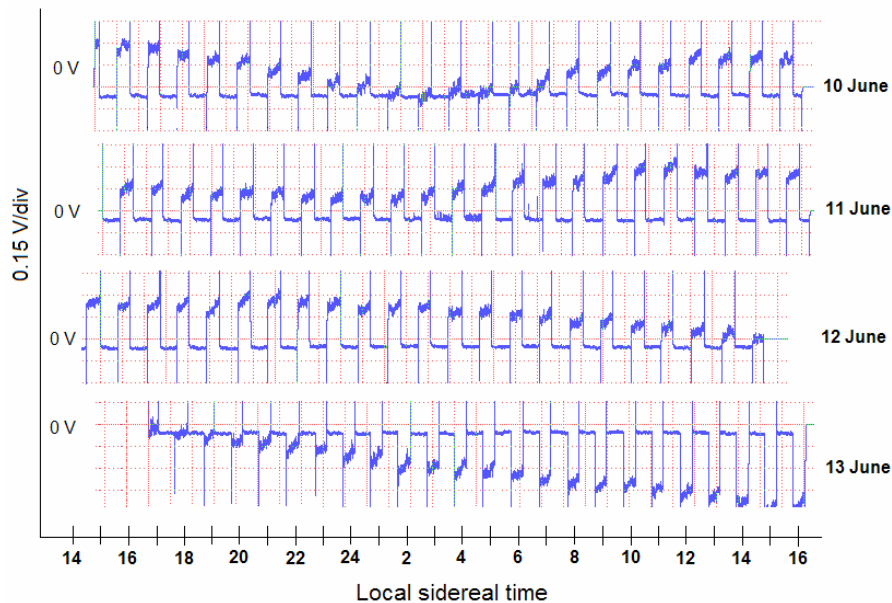

Fig. 5 First measurement results from June 10 to June 13 2010. The LED source was 30 min ON and 30 min OFF.

The orientation of the optical channels is opposite to the orientation of the Miller and other MM experiments, therefore the minimum of the diurnal cycle in Miller’s experiment should correspond to the maximum of our experiment. Since the solar system velocity is larger than the Earth orbital velocity, the extremum position in the diurnal cycle does not change much when plotted against the LST (Local Sidereal Time). In Miller’s data [9] (Fig. 26) the minimum for April is at 14.5 hr LST and for August at 16 hrs LST. Interpolating for June it will be at 15.25 LST. In our observations on June 10 and 11, this corresponds to a maximum (we have a reverse direction) that is pretty close to this value. This is in agreement also with the Esclangon experiment, Gallae experiments and R. Cahill experiment. There was a new Moon on June 12. We may speculate that the large change of the signal on June 12 and 13 could be from the gravitational influence of the Moon or some gravity wave effect as discussed hereafter. The other preliminary observations were interrupted for adjustment purposes. They are filtered out because it was found that once the optical

part is adjusted, it's cover should not be opened since a slight resettlement of some dust on the optics influences the measurements.

Additionally short and long time fluctuations were observed that are not caused by the instrument or surrounding environments. Such fluctuations are apparent in all ether-drift experiments. According to Cahill they are from gravitational waves causing the day to day variations that are not contributed by the velocity components [33]. They are probably caused by processes in the Sun. This makes sense from the point of view of an Ether concept that defines the propagation of gravity and the speed of light. Therefore, if such gravity waves exist, a time fluctuation will also exist. This is in agreement with recent observations of time fluctuation estimated by variations in radioactive decay [34]. Another signature of a possible time fluctuation could be the unexplainable period fluctuation observed in pulsars known as pulsar timing noise or pulse frequency change [35]. According to Kosmogorov, it is of cosmological origin but it may also have a local component.

The proposed instrument will be enclosed in a sealed housing and upgraded with an optically stabilized LED source as described in the previous section. A new powerful LED source XRE7090WHTQ4 with brightness of 100 lm is planned to be used. If the long time data accumulation reveals the detection of light-speed anisotropy with a higher confidence level, the unexplained effect found by Cahill will also be answered. Cahill used fiber optics for a reference channel and claimed that the light velocity in the fiber optics is not affected by the Earth motion, while in the coaxial channel it is affected [21]. The effect is explained by assuming that both are affected but with different degree, so the case becomes similar to our experiment. The multiple internal reflections of the light in the fiber optics depends on the refractive index ratio of the glass and the clad, so the effect is similar to what was discussed in Section 3. Therefore, these kinds of experiments will be suitable for detection of direction of light speed anisotropy but not for estimation of the actual speed of the earth motion.

From the short-time data and their correlation with the Miller, Esclangon, Galaev, Cahill and R. de Witte [33] data, we see that the direction of the velocity vector of the non-null effect does not coincide with the direction of the CMB anisotropy. One possible explanation of this result is based on the different cosmological concept discussed by S. Sarg in [27,28] that is closer to Einstein's idea about a static universe.

## 5. Summary and conclusions

Presently, there are insufficient data for investigating the discrepancy between light speed anisotropy and anisotropy of CMB radiation. The proposed laboratory experiment is portable and not very expensive. More reliable and correlated data could be accumulated if it is implemented in different geographical locations. It could also be used in the Pulsar observatories to look for a possible correlation with pulsar timing noise.

I express my special thanks to William Treurniet for the useful discussions and Nikolaos Balaskas from York University for the encouragement and help with some optical components.

## References

1. T. F. Howell and J. R. Shakeshaft, Measurement of the Minimum Cosmic Background Radiation at 20.7 cm Wave-length, *Nature*, v. 210, 1318-1319, (1966)
2. D. T. Wilkinson and R. B. Partridge, Large Scale Density Inhomogeneities in the Universe, *Nature*, v. 215, 719, (1967).
3. J. M. Stewart and D. W. Sciama, Peculiar Velocity of the Sun and its Relation to the Cosmic Microwave Background, *Nature*, v. 216, 748-753, (1967).
4. E. K. Conklin, Velocity of the Earth with Respect to the Cosmic Background Radiation, *Nature*, v. 222, 971-972, (1969).
5. G. F. Smoot et al, Detection of Anisotropy in the Cosmic Blackbody Radiation, *Physical Review Letters*, v. 39, No. 14, 898-901, (1977)

6. C. L. Bennett et al., First-Year Wilkinson Microwave Anisotropy Probe (WMAP) Observations: Preliminary Maps and Basic Results, *The Astronomical Journal*, Supplement Series, 148:1-27, (2003).
7. B. Nodland and J. P. Ralson, Indication of Anisotropy in Electromagnetic Propagation over Cosmological Distances, *Physical Review Letters*, v. 78, No. 16, 3043-3046, (1997).
8. A.A. Michelson and E.W. Morley, On the Relative Motion of the Earth and the Luminiferous Ether, *Am. J. Sci.* 34, 333-345 (1887)
9. D. Miller, The Ether-Drift Experiment and the Determination of the Absolute Motion of the Earth, *Review of Modern Physics*, v. 3, 203-241, (1933).
10. A. A. Michelson, F. G. Peas and F. Pearson, Repetition of Michelson-Morley Experiment, *Nature*, v. 123, 88, (1929).
11. E. Esclangon, *Comptes Rendus*, v. 185, 1593, (1927).  
[http://www.conspiracyoflight.com/Esclangon/Aberration\\_and\\_Esclangon.html](http://www.conspiracyoflight.com/Esclangon/Aberration_and_Esclangon.html)
12. [http://en.wikipedia.org/wiki/Michelson-Morley\\_experiment](http://en.wikipedia.org/wiki/Michelson-Morley_experiment) (Table of experiments)
13. R. J. Kennedy, A refinement of the Michelson-Morley Experiment, *Nt. Acad. Sci. Proc.*, v.12, 621-629, (1926)
14. K. K. Illingworth, A repetition of the Michelson-Morley Experiment using Kennedy's Refinement, *Physical Review*, v. 30, 692-696, (1927).
15. S. Marinov, Measurement of Laboratory's Absolute velocity, *General Relativity and Gravitation*, v. 12, No. 1, 57-65, (1980).
16. E. W. Silvertooth, Experimental detection of the ether, *Speculations in Science and Technology*, v. 10, No 1, 3-7, (1986).
17. Yu .M. Galaev, Etheral wind in experience of millimetric radiowaves propagation, *Spacetime & Substances*, V. 2, No 5, 211-225, (2001)
18. Yu .M. Galaev, The measuring of Ether-drift velocity and kinematic Ether viscosity within optical waves band, *Spacetime & Substances*, v. 3, No 5, 207-224, (2002).
19. M. Consoli and E. Constanzo, Motion toward the Great Atractor from an ether-drift experiment, *arXiv:astro-ph/0601420* v. 2, (2006) (analysis of 3 Modern laboratory experiments, two in Germany and one in Australia, based on active and cryogenic optical resonators).
20. C. E. Navia et al, Search for Anisotropic Propagation as a Function of Laser beam Alignment Relative to the Earth's velocity Vector, v.1, *Progress in Physics*, 53-60, (2007).
21. R. T. Cahill, A New Light-Speed Anisotropy Experiment: Absolute Motion and Gravitational Waves Detected, *Progress in Physics*, v. 4, 73-92, (2006).
22. R. Hatch, Clocks and Equivalence principle, *Foundation of Physics*, v. 34, No11, 1725-1739, 2004.
23. Those scandalous clocks, *GPS Solutions*, 8:67-73, Springerlink.com, (2004)
24. R. Wang and R. H. Hatch, Conducting a Crucial Experiment of the Constancy of the Speed of Light Using GPS, *Infinite Energy*, 11, 64, 11-19, (2005).
25. C. K. Whitney, Is Optical Detection of linear velocity possible?, *Infinite Energy*, issue 69, 24-33, (2006)
26. R. R. Hatch, Contesting and testing infinitesimal Lorentz transformations and the associated equivalence principle, *Physics Essays*, 23, 1, 137-143, (2010)
27. S. Sarg, A Physical Model of the Electron according to the Basic Structures of Matter Hypothesis, *Physics Essays*, vol. 16 No. 2, 180-195, (2003)
28. S. Sarg, *Basic Structures of Matter – Supergravitation Unified Theory*, Trafford Publishing, 2006, ISBN 1412083877
29. G. Thuillier and M. Herse, Thermally stable field compensated Michelson interferometer for measurement of temperature and wind of the planetary atmosphere, *Applied optics*, v.30, No 10, 1210-1220, (1991).
30. G. Shepherd et al., The Wind Imaging Interferometer,
31. S. Marinov, *Progress in Physics*, v.1, 31-37, (2007)
32. F. Ahmet, B. M. Quine, S. Sargoytchev, A. D. Stauffer, A review of one-way and two-way experiments for test of isotropy of the speed of light, <http://arxiv.org/abs/1011.1318>
33. R. Cahill, The Roland De Witte 1991 Experiment (to the Memory of Roland De Witte), *Progress in Physics*, v.3, 61-65, (2006).
34. J. H. Jenkins and E. Fischbach, Perturbation of Nuclear Decay Rates During the Solar Flare of 13 December 200, <http://arxiv.org/abs/0808.3156v1>
35. D. A. Hemberger and D. R. Stinnebring, Scintillation & Pulsar Timing: Low-Level Timing Noise from the Kolmogorov Halo, *Chin. J. Astron. Astrophys. V. Suppl.* 2, 1-4, (2006).
36. V. H. Hoteev, Discussions about the Universe (In Russian), St. Petersburg, (2004)