

On Two New techniques for Gravitational Waves

Dhananjay P. Mehendale

Sir Parashurambhau College, Tilak Road, Pune 411030,
India

Abstract

We propose two new novel techniques for detecting gravitational waves. First technique is based on detecting variation in angular speed of the system of two circular disks connected by a light rod, kept perpendicularly to incoming gravitational wave, in the y - z plane say. This dumbbell-like system is kept in y - z plane in free rotational motion with constant speed, and further in vacuum to avoid any dissipation, and with as much high speed as possible, such that it will be revolving around the axis of rotation parallel to say x axis that passes through the center of mass of this assembly of two disks connected by light rod. The idea to achieve variation in angular speed is based on the principle of conservation of angular momentum. The synchronization is arranged so that there will be elongation when the centers of circular disks are along the line parallel to y axis and contraction when the centers of circular disks are along line parallel to z axis. Due to conservation of angular momentum this must result in detectable variation in the otherwise constant angular speed in absence of gravitational waves passing through this apparatus. This variation in angular speed is to be measured to conclude the arrival of gravitational waves! The second technique that we propose is based on combination of Weber-like setup using single cylindrical bar to act as a resonant antenna as per the idea of Joseph Weber [1] and the scanning tunneling microscope (STM) based upon idea of generating current by tunneling [2]. This tunneling current is managed by setting up suitable potential difference between sharp tips of suitably fixed probes and surface of suspended Weber bar or its spherical version [3]. We propose to keep the STM probes rigidly fixed at a predefined suitable locations and at constant distance between tips and surface of suspended Weber bar or its spherical version. Now, STM works on simple idea of applying potential difference between surface to be scanned and the probe having a sharp tip producing tunneling current from tip of probe to surface or surface to tip of probe depending upon polarity. This current is further amplified for using it as input for image producing software. We give here a proposal to use this arrangement for the process of detecting gravitational waves. Even with very small change in size (length) of Weber bar or its spherical version on passing of gravitational waves we hope to get detectable change in the amplitude of amplified current. Due to contractions and expansions encountered with suspended Weber bar upon the passing of gravitational waves there can be detectable change in the quantity of tunneling electrons. responsible for quantity of current flowing between tip of probes and Weber bar or its spherical version. This idea of achieving detectable change in the amplitude of tunneling current on arrival and passing of gravitational waves, essentially because of variation in distance between probes fixed suitably at different locations and resonating Weber bar, may lead us to successful detection of gravitational waves!

1. Introduction: Experimental detection of gravitational waves is a big challenge of this time and enormous efforts are on world over by people working in highly sophisticated gravitational wave detection laboratories. Gravitational wave laboratories will be leading laboratories in the coming future to offer new important insights in our study of large scale phenomena. Detection and study of gravitational waves of different types and of different intensity and frequency will make revolutionary contributions to our knowledge about galactic dynamics. It will add greatly to our knowledge about astrophysical sources and about processes driven by strong gravitational fields. Objects of fundamental importance, such as astrophysical black holes, merge and radiate with luminosity larger than the entire electromagnetic universe, and these events will become clearly detectable only through a tool for detection of gravitational waves that are mainly associated with detectable amplitude with such unimaginably huge events [4]. When observed with gravitational waves these intrinsically interesting astronomical sources such as massive black holes and their merger, extremely compact stellar binaries and their collisions, supernovae events etc will surely yield many new surprises. Thus, the discovery potential associated with detection of gravitational waves is immense.

Gravitational radiation was detected indirectly in 1974 by J. Taylor and R. Hulse, who observed its effects on the orbital period of a binary system containing two neutron stars, one of them a pulsar (PSR 1913 + 16). Efforts to detect gravitational waves directly have been severely challenged by the extreme weakness of the waves impinging on the Earth. However, as the 21st century begins, observations of the gravitational waves from astrophysical sources such as black holes, neutron stars, and stellar collapse are expected to open a new window on the universe [5].

There are two major gravitational wave detection concepts: acoustic and interferometric detection [6]. The acoustic method deals with a resonance response of massive elastic bodies on gravitational wave excitations. Historically the acoustic method was proposed first by J. Weber [7] where he suggested using long and narrow elastic cylinders as Gravitational Wave Antennas. Although a significant progress has been achieved in fabrication and increasing sensitivity of such type of detectors [7, 8, 9] the interpretation of obtained data is still far to claim undoubtedly the detection of gravitational waves. Extraordinarily weak effect produced by gravitational waves requires exceedingly high detector sensitivity for both acoustic as well as interferometric detectors. Any new idea associated with marked improvement causing increase, may be in the indirect way, in the size of the quantity to be measured for getting conclusive evidence for the presence of gravitational waves will be a welcome thing.

2. Detection by Detecting Angular Speed Variation: As seen above one requires extraordinarily high sensitivity of detectors to conclusively capture the signal called gravitational waves. The first technique that we propose is aimed at changing focus from the direct detection of deformations produced in the resonant antenna to detection of variation in the angular speed caused as an effect of such deformations in the dumbbell-like rotating system described below. The angular speed can be so

arranged that it can have a sizable and so measurable change. The dumbbell-like system for our experiment consists of two circular discs joined by a lightweight, rigid, metallic rod, rotating freely with high but constant speed in ultra high vacuum, so that the system is free from any dissipation in rotational energy, at super cooled liquid helium temperature, around the axis that is passing perpendicularly through the center of mass. Suppose this system of discs joined by a rod lies in y - z plane and suppose this system of two discs joined together by a rod are rotating around the x axis or axis parallel to x axis and passing through center of mass with sufficiently high speed and this speed is constant. As long as this system is not exposed to any gravitational wave there will be no deformation of any kind, i.e. extension or contraction of lengths. But when a plane gravitational wave will be incident on this system perpendicularly the deformations will be introduced converting the circular shapes of discs into elliptical shapes. FIG.1 below shows the system of two discs joined by a lightweight rigid rod placed in y - z plane is rotating around x axis with constant and high angular speed, say ω . As long as no gravitational wave has arrived the system rotating with constant angular momentum can be maintained rotating with constant angular speed.

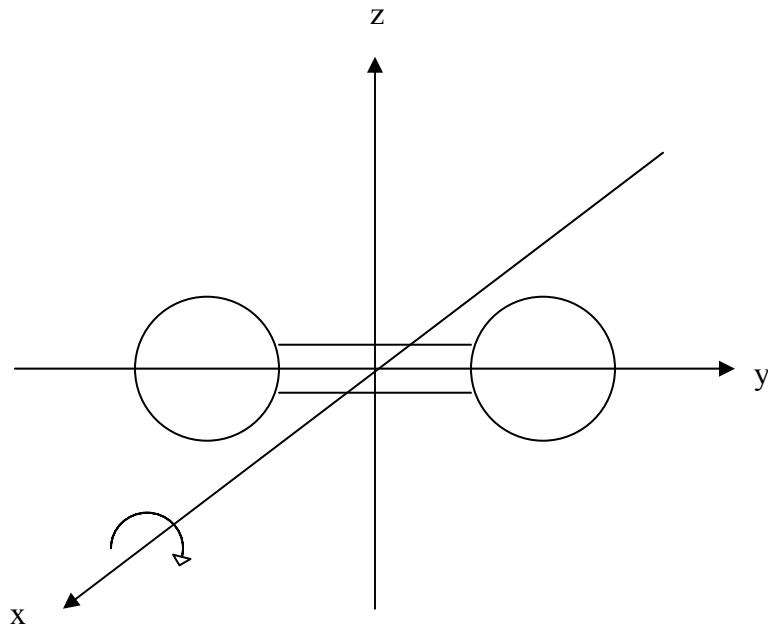

FIG.1

When a plane gravitational wave will start passing perpendicularly through this system due to successive contractions and expansions as an effect this incoming wave let there is expansion along y axis then the system will look like as shown in FIG.2 below.

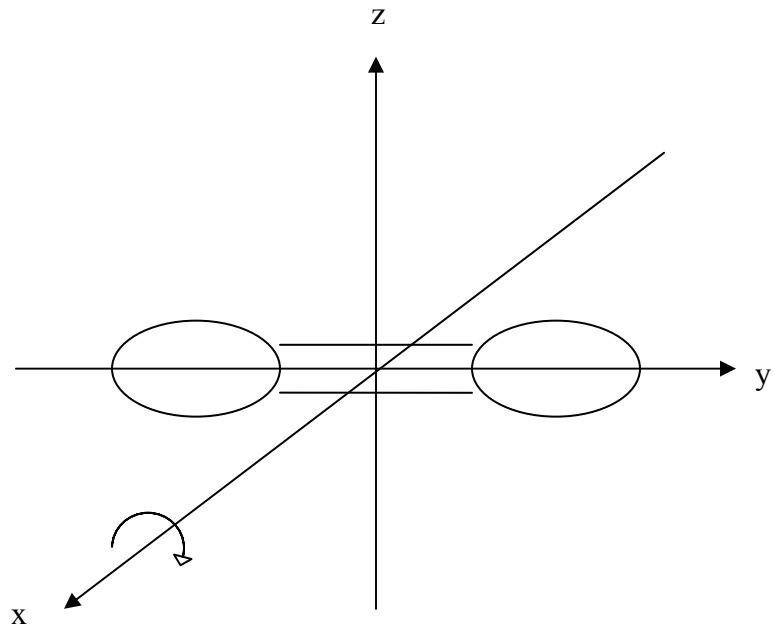

FIG.2

Further, when there will be contraction along y axis the same system will take the form as shown in FIG.3 below.

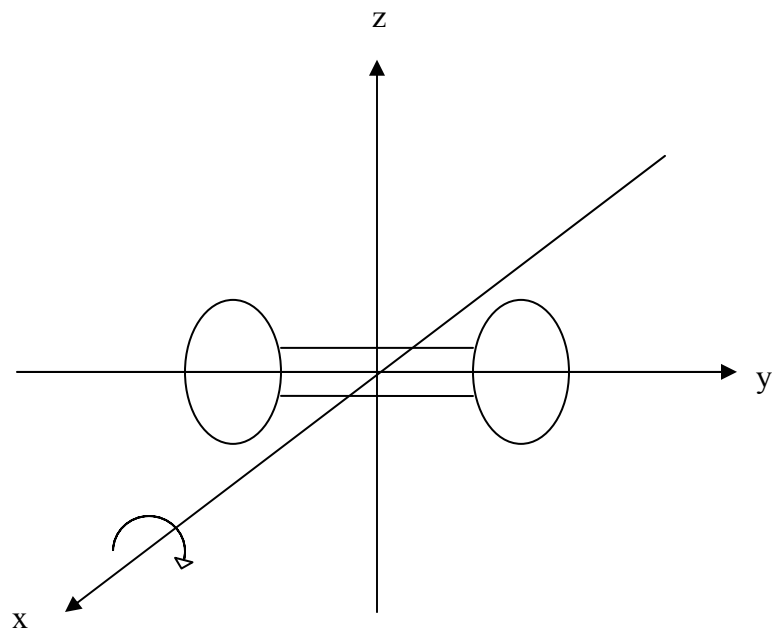

FIG.3

In the case corresponding to expansion shown in FIG.2 along y axis, the angular speed will go down as a consequence of the conservation of angular momentum due to increment in the distance between the centers of discs. On the other hand, in the case corresponding to contraction as shown in FIG.3 along y axis, the angular speed will go up again as a consequence of the conservation of angular momentum due to reduction of distance between the centers of discs.

We suggest developing appropriate technology to detect the possible sizable variation in angular speed that will result as a consequence of the conservation of angular momentum of our proposed system. Instead of focusing on improving the sensitivity of the present apparatus to capture exceedingly small variation in the lengths it could be worthwhile to shift our focus to detection of measurable change that is expected to arrive on passing of gravitational waves through suggested system.

3. Detection by Detecting Variation in the Tunneling Current: The main idea in brief behind this second technique suggested in this paper is to detect variation in the STM tunneling current due to contraction and extension of freely suspended Weber bar [1], or its spherical version [3] acting as resonant antenna, and rigidly fixed STM probes fixed at suitable location at very small and constant distance from the nearby surface of resonant antenna to capture the variation in the tunneling current due to variation in distance between tips of fixed probes and resonating Weber bar while a gravitational wave will pass through the apparatus. This idea is inspired by the idea of using quantum tunneling current for imaging surfaces. This powerful technique for viewing surfaces at the atomic level [2], developed in 1981 earned its inventors, Gerd Binnig and Heinrich Rohrer (at IBM Zürich), the Nobel Prize in Physics in 1986. In our case here, we will be using this technique based on using quantum tunneling to detect and measure the variation in the amplified tunneling current on account of expansions and contractions of suspended surface causing corresponding variation in distance between the fixed tips of the probes fixed at various locations and the surface of suspended resonant antenna while a gravitational wave will be passing through the apparatus. The STM technology has been developed on the basis of the concept of quantum tunnelling. When a conducting tip is brought very near to a metallic or semiconducting surface, a bias between the two can allow electrons to tunnel through the vacuum between them. For low voltages, this tunneling current is a function of the local density of states (LDOS) at the Fermi level of the sample. We suggest to measure variations in current as the suspended antenna surface oscillate causing change in its distance from the fixed probes at various convenient locations when gravitational waves pass through the system. This variation in tunneling current may further be translated into a kind of image, as usually is done to indicate presence and travel of gravitational wave.

The STM technology is now well established one and is one of the fascinating and successful technique widely used for imaging at atomic scale. Also, the recently undertaken development using spherical antenna, miniGRAIL [3], instead of bar type antenna used initially by Weber [1] has provided many advantages, like its marked increase in energy cross section, its equal sensitivity in all

directions etc. Using these two technologies in combination may hopefully be proved quite advantageous in our journey for capturing gravitational waves.

References

1. J. Weber, Gravitational-wave-detector Events, Phys. Rev. Lett. 20, 1307-1308, (1968).
2. G. Binnig, H. Rohrer “Scanning tunneling microscopy” IBM Journal of Research and Development **30**,4 (1986).
3. Spherical Gravitational waves detectors, miniGRAIL, Leiden, Holland, 2000-01.
4. Tom Prince (Lead Author for Members of the LISA International Science Team), The Promise of Low-Frequency Gravitational Wave Astronomy, 2010.
5. Joan M. Centrella, Laboratory for High Energy Astrophysics, Resource Letter GrW-1: Gravitational Waves, 2003.
6. G. B. Lesovika, A. V. Lebedeva, V. Mounutcharyana, T. Martinb, Detection of gravity waves by phase modulation of the light from a distant star, arXiv: astro-ph/0506602v1, 2005.
7. E. Amaldi et al., Nuovo Cimento, 7C, 338 (1984).
8. E. Amaldi et al., Nuovo Cimento 9C, 829 (1986).
9. P. Aston et al., Phys. Rev. D 47, 362 (1993).

Email: ghananjay.p.mehendale@gmail.com