

# Interpreting and Modeling the Photons

<sup>1</sup>Brian B.K. Min

Received:

**Abstract** To elucidate the hidden structure of photons, if any, we critically examine the following fundamentals to our physics: (1) Why is the speed of light constant in all frames of reference? (2) What is the empty space? (3) Is the space-time continuous and not discrete?

To pursue the above, needless to say without contradicting any observed phenomena, we postulate the space is an ocean of the “Gamma elements” having small energy and mass with the size given by the wavelength of an assumed cutoff, the highest energy gamma rays. This ocean of the Gamma elements is the medium for the electromagnetic field. Time and distance are both discretized by the process of light propagation from one Gamma element to the next with an electrodynamic process, suggested to involve spins and polarizations. This process allows a relativistically boosted internal kinetic energy, hence mass, to be generated. This postulate provides us with a theoretical basis to explain why the speed of light,  $c$ , should remain constant regardless of the observer’s inertial frames of reference. The theory describes light energy propagating as “elemental waves” with the phase velocity,  $c$ , in a way that is indistinguishable from the apparent photon particles traveling in vacuum. A photon is no longer a single particle with the energy  $h\nu$  travelling with the velocity  $c$ , but a Gamma element energizing with a frequency,  $\nu$ , to become each time a Planck element with the energy  $E_p = h/\nu$ , substantially behaving like a particle propagating with the phase velocity  $c$ .

A visualized space-time and photon models are presented and the Compton experiment and the double slit experiment are re-validated by the theory. In particular, the Compton scattering suggests a case that may help to verify the theory by an experimental measurement.

The uncertainty principle applicable to light is a natural consequence of the wave behavior of light but after an initial uncertainty, the quantum state of light may be predicted to an almost certainty within the limit only restricted by the discreteness of the space-time. It is conjectured that the Gamma element space corresponds to the dark energy and to Einstein’s cosmological constant. In addition, a Gamma element itself may be characterized as spin zero massive boson. It is not identified as Higgs boson but possibly as an alternate Higgs boson since the conjectured energy level of a Gamma element is far lower than that of the Higgs.

**Keywords** Light · Photon · Space · Time · Element · Particle · Quantum · Field

---

<sup>1</sup> Brian B.K. Min, Ph.D  
e-mail: bmin@nubron.com

## 1 MOTIVATION

According to the quantum field theory of the Standard Model, photons are the quanta of an electromagnetic field [1-3] with energy  $\mathcal{E} = h\nu$ . ( $h$  is the Planck constant,  $\nu$  is frequency.) They are also massless gauge bosons with spin one. While mathematically expressed, this picture is hardly visualized. Still to explain is how a particle can vary its internal energy,  $h\nu$ , as a function of  $\nu$  while the velocity is kept constant at  $c$ . Does a photon have a hidden structure? It is desirable to elucidate the hidden structure, if any, of a photon to better explain how light works: how light is a wave and a particle at the same time or when it is a wave and when a particle, and how it changes the energy.

We are clearly having difficulties with combining the quantum mechanics and special relativity since our conclusions are often contradictory. For example, photons possess momentum and energy but are massless hence nothing (zero rest mass) acquires a kinetic energy when moving at the speed of light. The space is a field with a vacuum state but without a medium, light waves propagate without a medium, and the electromagnetic and the gravity fields occur without a medium. Some fundamental issues that are related to these difficulties perhaps include the following.

First Issue:

That the speed of light is constant regardless of the frame of reference has been experimentally proven [4], which is a bedrock principle of the special relativity [5]. It is a cause, not a result, of the Lorentz transformation hence of the Maxwell's equation for the electromagnetic field. But we have no understanding why the speed of light should be constant regardless of the frames of reference. How is it possible that the speed of light be constant regardless of the frames of reference?

Second Issue:

At present we assume the space is empty, a "vacuum," so that the photons can travel through it with the speed of light. But light retains the wave characteristics which require a medium. Feynman [6] explains the situation as following: the electromagnetic field can carry waves; some of these waves are light, but that at higher frequencies they behave much like particles, and that quantum mechanics unifies the idea of the field and its waves, and the particles all into one. Wilczek [7] expands this and includes a vision of the primary ingredient, the "grid," that fills our space and time, is alive with quantum activity albeit spontaneous and unpredictable, contains material components, gives space-time rigidity, causes gravity, and weighs. Both descriptions are close to a revival of aether, but the luminiferous aether hypothesis has been put to hibernation by the special theory of relativity which does not require such things. Conjectures for the existence of the aether has persisted throughout the physics history [8] and our characterization of space is far from complete as testified by these historical developments.

Third Issue:

We quantize light and quantize everything, but the space-time continuum is considered given [9]. To the author's knowledge, we have never questioned the continuity of space and time itself even while the quantum theory is being developed. What is the basis for assuming our time and distance are continuous quantities with limitless resolution?

## 2 THE DEFINITION OF TIME AND DISTANCE

Newton's laws for the gravity and optics were built on an absolute space and time which does not require an observer's participation. The theory of relativity, however, was derived by requiring that a phenomenon obey the same law of physics regardless of any reference frames. In his thought experiments, Einstein relied on an observer for a clock and an observer in an accelerating elevator that led to new definitions on simultaneity and gravity, respectively. We find that how an observer sees drives the laws of the physics, so the use of an observer can be a powerful tool for discovering a physics principle.

In this vein, we ask what the space and time is to an observer which is us or more generally all life. We now critically examine the notion that the time and distance are continuous and that we have an innate ability to detect them on a continuous basis. It is then reasoned below that the discrete nature and the very definitions of time and distance to an observer may be the reasons for the constancy of speed of light.

We first examine how we hear and see, i.e., perceive the frequency (tones) of sound and the frequency (color) of light, albeit within a limited range. In both cases, the simplest way of achieving this is to count the number of waves (or wavelengths) of reference sound and reference electromagnetic waves, respectively. The same may be true with time and distance. We can measure the distance and the time by counting the number of waves taken for a reference light to travel between any two points. We can now postulate that our internal bio-clock functions in this simple way and indeed we function and age based upon such bio-clocks. It is unthinkable that we have any way of perceiving time and distance on a continuous basis without limit to the resolution.

Our next task then is to find the reference light. While any electromagnetic waves can be our reference light for the purpose of measuring the time and distance, we must find the most fundamental one, if any, to provide a measure for the smallest time and length scale. (We ignore the Planck scales for the moment for the reasons to be apparent below.) Among all observed electromagnetic wave spectrums, the gamma-rays possess the highest energy levels hence the highest frequencies and the shortest wavelengths. Although there is no known limit to the energy levels for the gamma-rays [10], the observation so far may suggest otherwise, because to this date we have not observed any gamma ray energy higher than approx. 10 TeV [11]. Accordingly we postulate that we are reaching, if already we have not, a cutoff energy level, so we know approximately (or within several orders of magnitude) the shortest wavelength our nature provides, and that there are fundamental elements associated with it. We will call them Gamma elements which must then be the media for the propagation of electromagnetic waves.

### 3 ELEMENTAL SPACE-TIME

Our space is postulated to be an ocean filled with "Gamma elements" having extremely small mass, energy, and dimensions. It is a conjecture at this time, only to be justified if such a postulate helps explain the difficult problems of our physics with no contradiction to any of the observed phenomena. Light propagates through the Gamma elements by energizing them with a process involving spins and relativistic boost of internal energy. (A plausible process is discussed in Section 4.2.) The Light propagation through Gamma elements defines the relative space and time. The Gamma elements are a form of matter, but we have never directly observed their existence because their density is extremely low, having no kinetic energy, no spin unless energized.

Much about the Gamma elements must be learned by future research, including their relationship with observable matters and their roles for the quantum and gravitational fields. Some of them are discussed in the following. Here it suffices to assume that each Gamma

element occupies a cubicle of space with a linear dimension  $l_p$  and a volume  $l_p^3$ . In this sense, it is similar to Wilczek's grid. Then the distance between two neighboring Gamma elements is also  $l_p$ . Furthermore, the time required for light energy to propagate from one Gamma element to the next is the elemental time interval, which we will denote  $t_p$ . Thus  $t_p$  and  $l_p$  are the elemental units of time and length, respectively, and  $l_p/t_p \equiv c$  defines the speed of light propagation.

In this respect, the Gamma element space differs from the absolute aether space although both share a requirement that they are the media of "light wave" propagation. There are also many historical conjectures that support the presence of aether for various reasons. A summary list may be found in [8]. Never before, however, to the author's knowledge it was suggested to explain the constancy of the speed of light.

In the following we will show the two conditions of special relativity, the principle of relativity and constancy of the speed of light, are both captured by the assumption that our space-time is discretized and that  $l_p/t_p \equiv c$  by definition in all inertial frames. We will call the latter the principle of elemental space-time (EST), or simply the EST condition. This asserts that the elemental length and time are the smallest units of length and time, respectively, and that we, the observers, merely count the number of  $l_p$  and  $t_p$  to perceive the distance and time, respectively. The magnitudes of  $l_p$  and  $t_p$  may change by the relativistic effect but their counts don't, hence the constancy of the speed of light. (This will be formulated in Section 3.2.)

To explore this further, let us build a bridge between the continuum physics and the elemental space-time. Now let  $n_s$  be the number of the Gamma elements energized per "second" by light, i.e., 1 second =  $n_s t_p$ . The distance traveled by light in one second is then  $n_s l_p$ . The speed of the light propagation then is calculated to be

$$c = \frac{n_s l_p}{n_s t_p} = \frac{l_p}{t_p}, \quad (1)$$

which is constant in all inertial frames.

When a Gamma element is loaded with light energy, we shall call it the Planck element. The lifetime of a Planck element is  $\approx t_p$ . The following analysis which we will call "discretizing" transforms an equation having the measurement units meter (m), kilogram (kg), and second (s) to one having the elemental units  $l_p$ ,  $M_p$ , and  $t_p$  according to the principle of the elemental space-time. ( $M_p$  will be defined later.) First we explicitly write an equation to include the customary units, converts the customary units to the elemental units, and then apply the EST condition. It is not a mere dimensional analysis but an exact analysis.

Let  $c$  (m/s) =  $c_0$  m/s where  $c_0$  is dimensionless number. We then have one light-second length =  $c_0 m = n_s l_p$ . We will also frequently use 1 m =  $n_m l_p$  where  $n_m = n_s/c_0$ .

Let  $h = h_0 \text{ kg m}^2 \text{ s}^{-2} \text{ s}$  and  $\nu = \nu_0 \text{ s}^{-1}$  where  $h$  is the Planck constant,  $\nu$  the frequency, and  $h_0$  and  $\nu_0$  are dimensionless numbers. The energy of a "photon" (denoted by the subscripts  $ph$ ) with the frequency  $\nu$  is [12]

$$\begin{aligned} \mathcal{E}_{ph} &= h \nu \\ &= h_0 \nu_0 \text{ kg m}^2 \text{ s}^{-2} \\ &= h_0 \nu_0 \text{ kg } (n_m l_p)^2 (n_s t_p)^{-2} \\ &= h_0 \nu_0 \text{ kg } (n_m/n_s)^2 (l_p/t_p)^2. \end{aligned} \quad (2)$$

But  $n_m/n_s = 1/c_0$ ,  $l_p/t_p = c$ , thus

$$\mathcal{E}_{ph} = (h_0 \nu_0 / c_0^2) \text{ kg } c^2.$$

One recognizes that  $h_0 \nu_0 / c_0^2 \text{ kg}$  is a mass, hence let  $M_{ph} \equiv h_0 \nu_0 / c_0^2 \text{ kg} = h \nu / c^2$ , then

$$\mathcal{E}_{ph} = h\nu = M_{ph}c^2. \quad (3)$$

This derivation at once shows (1) the wave-matter equivalence and (2) the energy-mass conversion. How did we get this equation so easily? This shows the power of the EST principle,  $l_p/t_p=c$  which simplifies the mechanics of special relativity. (In this paper, we shall denote mass to be  $M$  to distinguish it from the length unit meter denoted by  $m$ . This is necessary since we are including physical units in our discretized equations.) Thus from the Planck relation and the elemental space-time model, we have derived the mass of the photon to be  $M_{ph} = h\nu/c^2$ . This contradicts our standard treatment that the photons travel with velocity  $c$ , are massless, and their energy is all kinetic. The above result indicates that a photon's mass is not a zero. Such a prediction was made previously by De Broglie [13] and we will back it up again in the following sections by a re-interpretation of the relativistic energy-momentum relation.

### 3.1 Estimate of Elemental Properties

For brevity, here we shall drop the subscripts “ph” from the designation of photon energy and photon mass, respectively. The Planck-Einstein relation  $\mathcal{E} = h\nu$  states that the energy of light is discretized. We can rewrite Eq. (3) as

$$\mathcal{E}(\nu) = h\nu = M(\nu)c^2. \quad (4)$$

This explicitly states that the energy of a photon is a function of frequency and its mass then is also a function of frequency. Since  $\nu_0$  is a positive integer, one recognizes that the elemental energy,  $E_p$ , is obtained when this is the smallest, i.e., when the frequency is one per second,

$$\mathcal{E}_p \equiv \mathcal{E}(1) = \frac{h}{s}, \quad (5)$$

This states that the energy of light may be converted to mass, a function of frequency  $\nu$  with an elemental value when  $\nu=1$ :

$$M_p \equiv M(1) = \frac{h}{c^2 s}. \quad (6)$$

$M_p$  is the mass of a Gamma element when loaded with the light energy. For distinction, we shall call an energized Gamma element to be the Planck element.  $M_p$  may be considered to be the rest mass of a Planck element having a lifetime of  $t_p$ . Its value may be calculated from the above,

$$M_p = 7.37 \times 10^{-51} \text{ kg}.$$

We can also write for the energy of a Planck element,

$$\mathcal{E}_p = M_p c^2. \quad (7)$$

Thus according to the present model, a photon is a Gamma element located at a point beating  $\nu_0$  times per second, i.e., Planck elements each with lifetime  $t_p$  appearing  $\nu_0$  time per second. Mathematically, however, a photon may be visualized as a  $\nu_0$  number of Planck elements arriving to a point in series with the velocity,  $c$ , or even single particle with energy  $h\nu$  arriving with the velocity,  $c$ . A difficulty with the idea of a photon being a single particle with energy,  $h\nu$ , and travelling with the velocity,  $c$ , is that, by the energy-mass equivalence expressed in the above equation, the mass of photon changes every time  $\nu$  changes. An elementary particle like photon must not change the mass, hence we must declare the mass of a photon is zero. Indeed, the definition of photons as massless particles always travelling with the velocity  $c$  and having momentum and energy with spin one, underlies the description of all elementary particles in our Standard Model.

Whereas the mass of the Planck element is deduced from the Planck constant, we don't find an experiment from which to deduce the values  $l_p$  and  $t_p$ . We note, however,  $l_p$  must be a true lower bound, cutoff wavelength of electromagnetic waves. We are now led to assuming such lower bound cutoff wavelength (or the upper bound cutoff frequency) exists and that it may be deduced from known measurements. We find the smallest electromagnetic wavelength that has been experimentally observed or projected comes from the ultrahigh energy gamma rays [14-16] in the range,

$$\lambda_{\gamma\text{-ray}} \approx 1 \times 10^{-19} \text{ m} - 1 \times 10^{-25} \text{ m}.$$

We then deduce

$$l_p = 1 \times 10^{-19} \text{ m} - 1 \times 10^{-25} \text{ m}$$

hence

$$t_p = l_p/c = 3.34 \times 10^{-28} - 3.34 \times 10^{-34} \text{ s}.$$

(We exclude the cosmic rays as they are not the electromagnetic waves [17, 18].) We note that these elemental units,  $l_p$ ,  $M_p$ , and  $t_p$ , have origins and values unrelated to the conventional Planck units [19] although their dimensional relationships are the same [20].

### 3.2. Compatibility with the Lorentz Transformation

By using the EST principle,  $l_p/t_p = c$ , we can easily derive the discretized Lorentz transformation as the same can be readily derived from the conditions of special relativity, i.e., the principle of relativity and  $c$ =constant in all inertial frames [21]. In the following, we only show what form the Lorentz transformation must take once discretized by the EST. Let the first inertial frame  $S'$  move relative to another inertial frame  $S$  with the velocity,  $v$ , in the  $x$ -direction. The coordinates,  $x$ ,  $y$ , and  $z$ , are interchangeable with  $x^i$ ,  $i = 1, 2, 3$ , respectively.  $S$  then moves with the velocity  $-v$  in the  $x$ -direction relative to  $S'$ . A particle  $P$  is described by the observer in  $S'$  as  $P(ct', x', y', z')$  and by the observer in  $S$  as  $P(ct, x, y, z)$ ,

$$x^\mu \equiv (x^0, x^1, x^2, x^3) = (ct, x^1, x^2, x^3) \quad (8)$$

and

$$x'^\mu \equiv (x'^0, x'^1, x'^2, x'^3) = (ct', x'^1, x'^2, x'^3). \quad (9)$$

The Lorentz transformation describes the relationship between these two coordinates as following [1,2, 21]:

$$x'^\mu = \Lambda_\nu^\mu x^\nu, \quad (10)$$

where

$$\Lambda = \begin{bmatrix} \gamma & -\gamma\beta & 0 & 0 \\ -\gamma\beta & \gamma & 0 & 0 \\ 0 & 0 & 1 & 0 \\ 0 & 0 & 0 & 1 \end{bmatrix}, \quad (11)$$

$$\beta = v/c, \text{ and } \gamma = 1/\sqrt{1 - \beta^2}.$$

The inverse relationship is

$$x^\mu = \Lambda^{-1\mu}_\nu x'^\nu, \quad (12)$$

where

$$\Lambda^{-1} = \begin{bmatrix} \gamma & \gamma\beta & 0 & 0 \\ \gamma\beta & \gamma & 0 & 0 \\ 0 & 0 & 1 & 0 \\ 0 & 0 & 0 & 1 \end{bmatrix}. \quad (13)$$

To discretize the above, let us first recognize that the Gamma elements must fill space in an isotropic and homogeneous manner. We assume the elemental length  $l_p$  to be independent of directions, for from  $l_p/t_p = c$  we get  $l_p$  to be proportional to  $t_p$ , an elemental time that we assume to be independent of directions. Hence we can discretize the space-time coordinates:  $x = n_x l_p$ ,  $y = n_y l_p$ ,  $z = n_z l_p$ ,  $ct = cn_t t_p = n_t l_p$ ,  $x' = n_x' l_p$ ,  $y' = n_y' l_p$ ,  $z' = n_z' l_p$ , and  $ct' = cn_t' t_p = n_t' l_p$  where  $n_x, n_y, n_z, n_t$ , etc. are dimensionless integers, or

$$x'^{\mu} = l_p' n'^{\mu}, \quad x^{\mu} = l_p n^{\mu} \quad (14)$$

By discretizing and rearranging Eqs. (10) and (12), we get

$$l_p' n'^{\mu} = \Lambda_{\nu}^{\mu} l_p n^{\nu}, \quad l_p n^{\mu} = \Lambda_{\nu}^{-1\mu} l_p' n'^{\nu} \quad (15)$$

or

$$l_p' n'^{\mu} = (\mathcal{N}_p) \frac{\Lambda_{\nu}^{\mu}}{\gamma} n^{\nu}, \quad l_p n^{\mu} = (\mathcal{N}_p') \frac{\Lambda_{\nu}^{-1\mu}}{\gamma} n'^{\nu} \quad (16)$$

For the velocity of light,  $c$ , to be constant in all inertial frames, we must have  $n'_x = n_x$  and this is possible only if

$$n'^{\mu} = \frac{\Lambda_{\nu}^{\mu}}{\gamma} n^{\nu}, \quad n^{\mu} = \frac{\Lambda_{\nu}^{-1\mu}}{\gamma} n'^{\nu}. \quad (17)$$

We then have

$$l_p' = \mathcal{N}_p, \quad l_p = \mathcal{N}_p' \quad (18)$$

and by dividing both sides by  $c$ ,

$$t_p' = \mathcal{N}_p, \quad t_p = \mathcal{N}_p'. \quad (19)$$

According to the EST, the above results, Eq. (17)-(19) can be interpreted as following. A Lorentz transformation between two elemental space-time frames consists of the  $\gamma$ -boost of the size of the Gamma element in an isotropic and homogeneous manner and the unboosted Lorentz transformation of the number of Gamma elements.

The invariant, spherical wave-front relationship [1, 5],

$$x'_{\mu} x'^{\mu} = x_{\mu} x^{\mu} \text{ or } c^2 t'^2 - x'^2 - y'^2 - z'^2 = c^2 t^2 - x^2 - y^2 - z^2, \quad (20)$$

reduces to a discretized form,

$$n'_{\mu} n'^{\mu} = n_{\mu} n^{\mu} \text{ or } n_t'^2 - n_x'^2 - y_y'^2 - z_z'^2 = n_t^2 - n_x^2 - y_y^2 - z_z^2. \quad (21)$$

#### 4 ELEMENTAL SPACE-TIME MODEL FOR LIGHT

Light manifests both the wave and particle characteristics, e.g., interference and diffraction vs. photoelectrons and Compton scattering. So long as the empty space is literally empty, however, these two characteristics are difficult to harmonize, for waves require a medium for propagation and particles require a free space to travel. The quantum mechanics does this, in Feynman's words, by unifying the field, its waves, and particles all into one. The keys to this unification include the uncertainty principle and the massless particles. In this section, we shall present a

light model in the Gamma-Planck element space-time to show it is naturally consistent with the wave-particle characteristics of light and may be easily visualized.

#### 4.1 Energy Momentum Relation for Light

In this section, we extract some of the prerequisite from an author's previous paper [22]. We can write the relativistic energy-momentum relation in terms of the total energy,  $E$ , and momentum,  $P$ , of a particle,

$$E^2 = P^2 c^2 + M^2 c^4 \quad (22)$$

where  $c$  is the speed of light and  $M$  the mass of the particle [23-25].

If we define  $\mathcal{E} \equiv M c^2$ , the internal energy (many authors call this the rest energy) and  $\mathcal{P} \equiv M v$  to be the non-relativistic momentum, we can then call  $E \equiv \gamma M c^2 = \gamma \mathcal{E}$  to be the

relativistic total energy and  $P = \gamma M v = \gamma \mathcal{P}$  to be the relativistic momentum where  $\gamma = 1 / \sqrt{1 - \frac{v^2}{c^2}}$

is the Lorentz factor,  $v$  is the velocity of the particle.

The energy-momentum relation, Eq. (22), may then be rewritten,

$$\mathcal{E}^2 = \mathcal{P}^2 c^2 + \frac{1}{\gamma^2} M^2 c^4, \quad (23)$$

in terms of the internal energy, non-relativistic momentum, and mass. We note that the equations (22) and (23) are of the same form except the mass  $M$  is replaced with  $M/\gamma$ , a relativistic mass or the mass normalized by the Lorentz factor, with  $0 \leq 1/\gamma \leq 1$ . The  $1/\gamma$  appears as a normalization factor; for instance each of the electron's orbits in an atom has a particular angular velocity and radius hence a characteristic  $\gamma$  and  $1/\gamma$  values. It, therefore, provides us with crucial information for the behavior of the particle. For any particle moving at the speed of light, Eq. (22) blows up but Eq. (23) behaves well and states that the kinetic energy dominates and the effect of mass goes to zero. This is the case for photons; the mass of a photon needs not be zero.

According to De Broglie [26], all matters have wave characteristics and their wavelength and frequency are, respectively,

$$\lambda_M = \frac{h}{P}, \text{ and} \quad (24)$$

$$v_M = \frac{cP}{h}.$$

We then have

$$E^2 = h^2 v_M^2 + (M c^2)^2. \quad (25)$$

The above  $\lambda_M$  and  $v_M$  represent relativistic matter waves and must not be confused with  $\lambda$  and  $v$  of the electromagnetic waves. We can use the latter to rewrite the above equation,

$$E^2 = \gamma^2 h^2 v^2 + (M c^2)^2 \quad (26)$$

where  $\gamma$  is due to the group velocity,  $v$ . The presence of the  $\gamma$  on the right hand side makes it consistent with the left hand side which is  $\gamma$ -boosted ( $E = \gamma M c^2$ ).

Furthermore we can rewrite the above equation as

$$(M c^2)^2 = h^2 v^2 + \left(\frac{1}{\gamma} M c^2\right)^2, \quad (27)$$



and when the particle velocity is the speed of light,  $v = c$ , we get

$$\mathcal{E} \equiv Mc^2 = h\nu. \quad (28)$$

This recovers Eq. (4), the energy equation for photons.

The above leads us to the mass of a photon,

$$M = \frac{h\nu}{c^2}. \quad (29)$$

In the limit when  $\nu = l/s$ , we get

$$M_p = \frac{h}{c^2 s}, \quad (30)$$

in agreement with Eq. (6).

In the standard interpretation of the photon, which derives from Einstein assumptions for photons,

$$P = \frac{h}{\lambda} \quad (31)$$

and

$$E = Pc. \quad (32)$$

Eq. (22) then tells us

$$M = 0 \quad (33)$$

and

$$E = h\nu. \quad (34)$$

It states that a kinetic energy is created from the zero rest mass  $M$ , i.e., something is created from nothing by moving the nothing at the speed of light. It is clear this awkward situation arises when a photon is assumed to be a particle travelling with the speed of light. Once it is understood per the EST that a photon is not a travelling particle, we can then easily accept that its rest mass is given by Eq. (29), and Eq. (34) should be replaced with Eq. (28).

To enable this, we must redefine photons, light waves, and the uncertainty principle for the light. From Eqs. (2) - (7), one sees that the energy of a photon is a function of the frequency  $\nu$  and that a photon with the energy  $\mathcal{E} = h\nu$  is a single Gamma element vibrating or spinning with a frequency,  $\nu$ , equivalent effectively to the  $\nu_0$  number of the Planck elements in series each carrying an energy  $\mathcal{E}_p = h s^{-1}$ . The corresponding mass of the Planck element is  $M_p = \mathcal{E}_p/c^2 = hs^{-1}c^{-2}$ , and the mass of the photon is then  $M = h\nu/c^2$ . It is natural for a stationary particle to have the internal energy and the corresponding mass. It is to be noted that a stationary particle with the internal energy is effectively the same as a hypothetical zero mass particle traveling with the speed of light having the same amount of kinetic energy, as in our standard treatment of photons. The present model, however, gives us a clearer picture of the internal workings of the photons. We will discuss this in more detail in the following sections. We will apply this photon model to the Compton scattering (see Section 5.1) to visualize the interaction between an x-ray and an electron.

De Broglie [26] first deduced Eqs. (24) by relating the mechanics for matters with optics but the same equations seem to have never been harmonized with photons. Despite the incorrectness of the photon being interpreted as a single particle traveling at the speed of light, an elemental wave propagating with the speed of light - the EST interpretation of light - is indistinguishable from a hypothetical photon particle travelling with the speed of light in most cases. In fact, mathematically one may treat any waves propagating with some phase velocity as particles with zero mass but with non-zero kinetic energy travelling with the phase velocity.

## 4.2 Application of the Quantum Field Theory to Photons in the Gamma Element Space

Following the treatise in [1], we can define a four vector potential,

$$A^\nu \equiv (V, \vec{A}) \equiv (A^0, A^1, A^2, A^3), \quad (35)$$

where  $V$  is a scalar potential,  $\vec{A}$  is a vector potential, and

$$J^\mu = (c\rho, \vec{J}), \quad (36)$$

where  $\rho$  is the charge density,  $\vec{J}$  is the current density. The Lagrangian density for the Maxwell field may be written

$$\mathcal{L} = -\frac{1}{16\pi} F^{\mu\nu} F_{\mu\nu} - \frac{1}{c} J^\mu A_\mu, \quad (37)$$

where  $F_{\mu\nu}$  is an electromagnetic field tensor,

$$F^{\mu\nu} = \partial^\mu A^\nu - \partial^\nu A^\mu. \quad (38)$$

We can then write the electromagnetic field equation or the Maxwell equation with a source current,  $J^\nu$ ,

$$\frac{1}{4\pi} \partial_\mu F^{\mu\nu} - \frac{1}{c} J^\nu = 0. \quad (39)$$

In the free space then,

$$\partial_\mu F^{\mu\nu} = 0. \quad (40)$$

With Lorentz gauge,

$$\partial_\mu A^\mu = 0, \quad (41)$$

the above becomes wave equations,

$$\partial^\mu \partial_\mu A^\nu = 0. \quad (42)$$

The wave nature of a free photon is then given by the solutions of the above in the form the vector potential wave,

$$A_\nu(x) = a e^{-ik \cdot x} \boldsymbol{\epsilon}_\nu^{(s)}, \quad (43)$$

where  $a$  is a normalization factor or the amplitude of the vector potential wave,  $\boldsymbol{\epsilon}_\mu^{(s)}$  is the polarization vector with  $s = 1, 2$  for the two spin states,  $k \cdot x \equiv k^\mu x_\mu$  where  $k_\mu = p_\mu / \hbar$ ,  $p_\mu = (E/c, \mathbf{p})$ , with a constraint  $p_\mu p^\mu = 0$ , or  $E = |\mathbf{p}|c$  and  $p_0 = E/c$ . The bold face indicates a three vector.  $k_\mu$  is the four wave number,  $p_\mu$  is the four momentum. By the Lorentz condition, Eq. (41), we have

$$p^\mu \boldsymbol{\epsilon}_\mu = 0, \quad (44)$$

and in the Coulomb gauge

$$\boldsymbol{\epsilon}^0 = 0, \quad \boldsymbol{\epsilon} \cdot \mathbf{p} = 0, \quad (45)$$

we may select two independent polarization vectors

$$\boldsymbol{\epsilon}^{(1)} = (1, 0, 0), \quad \boldsymbol{\epsilon}^{(2)} = (0, 1, 0), \quad (46)$$

By defining an integer variable  $n = (n_0, n_1, n_2, n_3)$ , we can discretize Eq. (43)

$$A_\nu(x) = a e^{-il_p k \cdot n} \boldsymbol{\epsilon}_\nu^{(s)}; (s = 1, 2) \quad (47)$$

or

$$A_\nu(n) = a e^{-ik \cdot n} \boldsymbol{\epsilon}_\nu^{(s)}; (s = 1, 2) \quad (48)$$

where  $a' = ae^{i p}$  is the amplitude of the elemental vector potential wave. This equation expresses the discretized nature of the EST model of light with the dimensionless integer four-vector space-time variable,  $n$ , replacing the continuous four vector space-time variable,  $x$ . In Fig. 1, the above four-vector potential wave propagating in the medium of Gamma elements is depicted in  $A_v$  ( $v=1, 2$ ) and  $n_3$  space. In a companion paper [27], the author showed by an alternate formulation of the quantum fields that the bosons transform between a massive and massless states when  $A_0 = \text{constant}$  and  $A_i = 0$  for  $i = 1, 2, 3$ . This is the Coulomb gauge condition except  $A_0 = \text{a non-zero constant}$  is selected instead of zero, which is also admissible for gauge invariance. This suggests a mechanism for the Planck element being created by the electromagnetic waves transforming the “massless” state of the Gamma element, a scalar boson, into the massive state, i.e., the Planck element, at each node during the propagation. These Planck elements are also shown in Fig. 1.

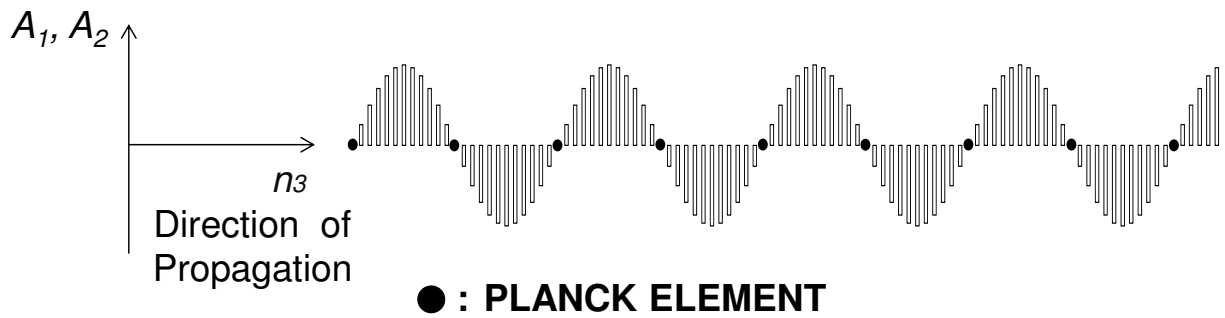

**FIG. 1** Gamma Elements are the Medium for the Electromagnetic Waves (or the Vector Potential Waves in the above); it is suggested that a Planck Element is “Created” at Each Node.

In applying the quantum field theory to the Gamma element space of the present theory, we note that the vacuum state in the quantum field theory is approximately equivalent to the Gamma element state, hence the massless state and massive state of a photon are equivalent to the Gamma element and Planck element, respectively. We also note that the vector potential waves or corresponding electromagnetic waves by themselves are not observable entities. Only by manifestation of the Planck elements the light rays become observable (or measurable.)

### 4.3 Modeling of Photons

The photoelectric effect and Compton scattering are explained by assuming light to be a single particle with energy  $h\nu$ , i.e., a photon. But from the EST we deduced a photon is a single Gamma element vibrating or spinning with a frequency,  $\nu$ , or equivalently Planck elements arriving with the same frequency. Can the photoelectric effect and Compton scattering be explained by such pictures of a photon instead of being a single particle with energy  $h\nu$ ? To answer this, consider a few thought experiments.

Let us first imagine a pair of billiard balls, A and B, of the same size and mass. Ball A travels a distance,  $L$ , with a momentum  $P_A=P$  before colliding with the stationary ball, B. Assuming an elastic collision, 100% of the momentum of A is transferred to B by the collision; we then have  $P_B=P$  and  $P_A=0$  after the collision.

We now extend this experiment by replacing the ball A by an  $N$  number of identical balls  $A_1-A_N$  aligned in series and each is  $(1/N)L$  distance apart from its neighbor. We push the first ball to impart the momentum,  $P$ , initiating a sequence of the first ball striking the second, the second

striking the third, etc., and finally the  $N^{\text{th}}$  ball,  $A_N$ , striking the ball B which now takes the full momentum  $P_B=P$ . For an observer who is with ball B, the ball  $A_N$  is indistinguishable from the ball A of the previous experiment because the effects of the two cases to B are exactly the same: a ball of the same mass arriving at the same speed striking the ball B with the same momentum. To this observer, the ball A is as if it travelled all the way through the space before striking the ball B.

We now further extend the above experiments. Let us spring mount each of the N balls,  $A_1$ - $A_N$ , so that each has a zero potential energy position to which it instantly returns after striking the ball ahead. Now we can push the first ball,  $A_1$ , repeatedly with a frequency  $\nu$  so that the momentum  $P$  arrives to B for a total momentum,  $\nu P$ . For an observer who is with ball B and who cannot see very far or very quickly, the only thing he perceives is the ball  $A_N$  striking the ball B with a frequency  $\nu$ . Since he cannot distinguish the ball  $A_N$  from the ball A, this is the same to him as the balls identical to A travelling through the distance,  $L$ , and striking the ball B with a frequency  $\nu$  for a total momentum  $\nu P$ . In short, this last thought experiments describes a wave propagation through the medium of billiard balls; yet the observer with the ball B may believe the ball A travels all the way along the distance,  $L$ , and this happens with a frequency,  $\nu$ .

From the above analogy, light propagation may be visualized as following: light is energy propagating through the Gamma element space at a constant phase speed. The light energy transmits from one Gamma element to the next, for instance by imparting spins. We shall call the energized Gamma element to be the Planck element since the energy of the latter is constant and deduced from the Planck constant. The energy of light is determined by the frequency of this occurrence. For this model, a photon is no longer a single particle with the energy  $h\nu$  travelling with the velocity  $c$ , but a Gamma element energizing with a frequency,  $\nu$ , to become each time a Planck element with the energy  $E_p = h\nu$ , and propagating with the phase velocity  $c$ , behaving effectively like a series of particles.

So far we have used  $\mathcal{E} = h\nu$  to be the energy of a photon, but for clarity here we shall again denote the energy of a single photon as  $\mathcal{E}_{ph}$ , i.e.,  $\mathcal{E}_{ph} = h\nu$ . With the above definition, we can write Eq. (5) as,

$$\mathcal{E}_{ph}(\nu) = h\nu = \mathcal{E}_p \nu \quad (49)$$

From the above and Eq. (6), we can also write

$$M_{ph}(\nu) = M_p \nu \quad (50)$$

for the mass of a photon  $M_{ph}$ .

Since a light ray is a stream of the photons, each being a packet of  $\nu_0$  number of Planck elements, we may generalize the above to obtain the energy of the light ray, or more generally the energy of electromagnetic waves, to be expressed as

$$\mathcal{E}(n, \nu) = nh\nu = nE_p \nu \quad (51)$$

and the mass of the same as

$$M(n, \nu) = nM_p \nu \quad (52)$$

where  $n$ , the measure of the intensity of light, is the average number of photons carried by the ray in a second.

In this way we visualize a light ray to be the  $n$  number of photons, each photon being a Planck element stream with a frequency,  $\nu$ , or a single Gamma element energizing with a frequency,  $\nu$ , behaving like a particle, or a “light quantum” as first characterized by Einstein [12].

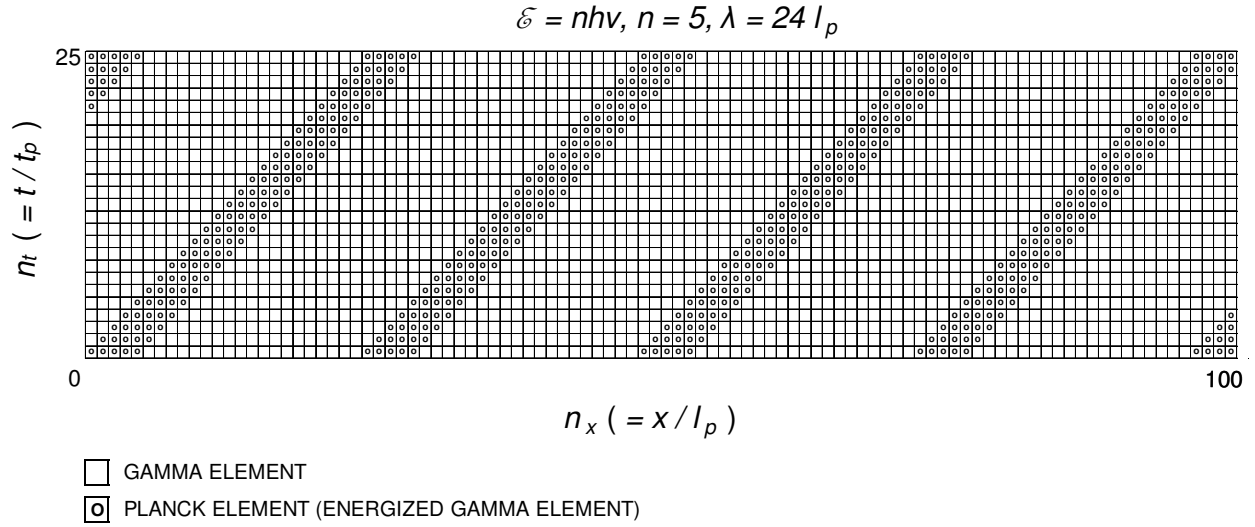

**FIG. 2** An Elemental Space-Time Model for Light

From this and the elemental space-time model, we can finally construct a simple and straightforward light model that helps to visualize the wave and particle characteristics. This is shown in Fig. 2. For clarity, the accompanying vector potential waves shown in Fig. 1 are not included in Fig. 2.

Here the elemental space-time is represented in non-dimensional units:  $n_x = x/l_p$  for space (horizontal axis) and  $n_t = t/t_p (= ct/l_p)$  for time (vertical axis). Only  $n_x = 1 - 100$  and  $n_t = 0 - 25$  are shown to fit in this page. We show light propagating in  $x$ -direction (horizontal axis) with the distance represented as  $n_x = x/l_p$  and time (vertical axis) represented as  $n_t = t/t_p (= ct/l_p)$ . In this dimensionless  $n_x - n_t$  space, a Gamma element is represented as an empty square and a Planck element as a square filled with o.

Illustrated as an example is the space-time model for an ultrahigh energy Gamma-ray with the wavelength  $\lambda=24l_p$  and the energy  $\mathcal{E} = nhc/(24l_p)$ , with  $n = 5$  or 5x the intensity of a photon.

This electromagnetic ray displays the frequency and wavelength that are characteristic of a wave. Thus the model visualizes both the particle behavior and wave nature of light. Nevertheless, this wave is unlike the solid or fluid waves whose energy is related with their usual amplitudes [28, 29]. Rather, the energy of each light ray is related with their frequencies only. The mass and energy of the Planck elements determine the particle behavior and their frequencies or wavelengths determine the wave behavior. The present model of light may be called the “elemental waves,” to distinguish it from normal solid and fluid waves. Complex rays may be manifested as a combination of simple rays. The behavior of the elemental waves will be further discussed in Section 5.

#### 4.4. A Model for the “Empty Space”

According to the elemental space-time model, the “empty space” is an ocean of the Gamma elements. In the language of the quantum field theories, the Gamma elements must be a spin zero massive boson. When excited, they become Planck elements and must have spin one since they are the elements of photons. If we freeze a volume of the space at any given time and represent it in two dimensions, it will look somewhat like Fig. 3. Again for clarity, the accompanying vector potential waves shown in Fig. 1 are not included in Fig. 2.

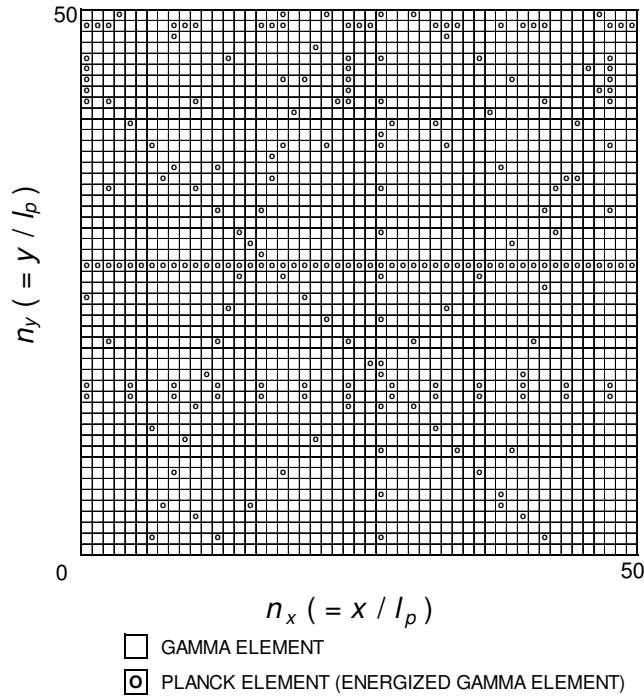

FIG. 3 An Elemental Space-Time Model for the “Empty Space” with Electromagnetic Waves in Random Directions (Represented in the  $n_x - n_y$  Plane.) The Density of Planck Elements over the Gamma Elements is Exaggerated.

It represents the space by  $n_x = x / l_p$  and  $n_y = y / l_p$  coordinates, counting the number of the Gamma elements in the horizontal and the vertical directions, respectively. Each  $l_p \times l_p$  square represents one Gamma element and each Gamma element filled with a circle represents a Planck element (signifying that the latter is an energized former.) The Planck elements represent the spatial distribution of light rays propagating in random directions, for in space electromagnetic rays are observed in every direction including the cosmic microwave background and from stars which are presumably infinite in numbers. The density of the Planck elements shown in Fig. 3 is exaggerated to illustrate the space model with a small number of the Gamma elements, only  $50 \times 50$ .

In Fig. 3, the highest energy gamma rays are represented by the horizontal ray with the wavelength  $\lambda = l_p$  (those with all the Gamma elements along the path energized to become the Planck elements.) In general, light rays with energy  $E = nhv = nhc/\lambda$  can be represented by  $(n, \lambda)$ .

Hence represented in this figure randomly are the ultrahigh energy gamma rays  $(1, l_p)$ ,  $(1, 2l_p)$ ,  $(1, 4l_p)$ ,  $(1, 5l_p)$ ,  $(2, 4l_p)$ , and  $(5, 24l_p)$ , etc. Light rays having higher wavelengths or more complex rays that may be constructed by the combination of simple rays may not be represented here both due to the size limitation and for clarity.

## 5 THE DUAL NATURE OF LIGHT

In this section, we will reinterpret the Compton scattering and the double slit interference from the viewpoint of the elemental space-time. It will be shown that the dual nature of light is a

natural consequence of the elemental space-time and light model. We follow the original calculation by Compton, rather than the more complete quantum electrodynamics (QED) calculation since the former is easier to visualize the photon structure. The latter does not offer any visualization of the photon structure. Here we ignore the spins, which is acceptable in the average sense.

### 5.1 The Particle Behavior of Light – Compton Scattering

For Compton scattering, both the QED and the original calculation by Compton [2, 30] produce the relationship between the wavelengths of the incident X-ray before and after the scattering

$$\lambda' - \lambda = \frac{h}{M_e c} (1 - \cos \theta), \quad (53)$$

or by the corresponding frequency relationship

$$\frac{\nu'}{\nu} = \frac{1}{1 + \alpha(1 - \cos \theta)}, \quad (54)$$

where

$\lambda$  and  $\nu$  are the wavelength and frequency of the incident primary X-rays (or  $\gamma$ -rays,) respectively,

$\lambda'$  and  $\nu'$  are the wavelength and frequency of the scattered X-rays, respectively

$M_e$  is the mass of the electron, and

$\theta$  is the scattering angle,

and

$$\alpha \equiv \frac{h \nu}{M_e c^2}.$$

The above equation is derived by assuming that both the X-ray photons and electrons are single particles and that their energy and momentum are conserved before and after collisions. Since the energy of the incident waves is  $h\nu$  and the energy of the scattered wave is  $h\nu'$ , with  $h\nu > h\nu'$ , the problem is the inelastic collision between the photon and the electron with the photon losing the energy by the collision. It is noted that for a given direction,  $\theta$ , the change in wavelength,

$$\Delta\lambda = \lambda' - \lambda,$$

is constant and does not depend on the frequency of the incident waves. In particular, for  $\theta = 90^\circ$  it is given by

$$\Delta\lambda(\theta = 90^\circ) = \lambda_c = \frac{h}{M_e c} = 2.43 \times 10^{-12} \text{ m},$$

where  $\lambda_c$  is known as the Compton wavelength. Since it is constant, the change in wavelength is noticeable only when it is not negligible compared with the wavelength of the incident electromagnetic waves.

In view of the present elemental space-time, the above equation may be derived by the conservation of momentum of an electron and the incident X-ray Planck element before and after the collision. In this way, the EST light model provides visualization to the phenomenon.

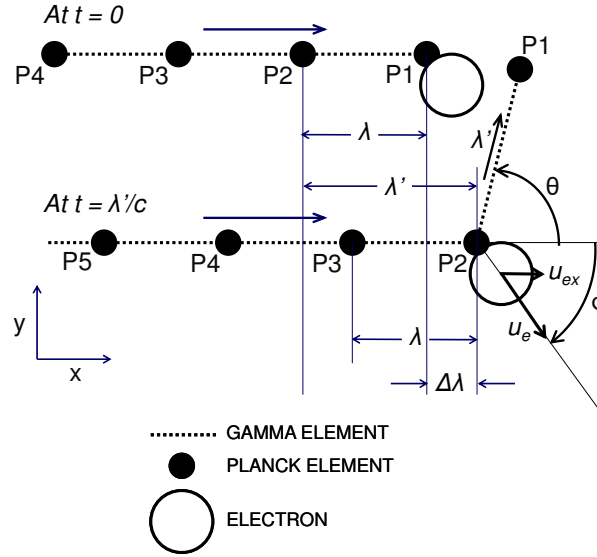

**FIG. 4** Illustration of the Compton Scattering  
(Not to Scale)

Fig. 4 illustrates the travel of five Planck elements, P1 - P5 in the x-direction until the leading Planck element P1 collides with an electron and then continues at an angle  $\theta$  after the collision. The distance between the adjacent Planck elements of the incident X-ray is the wavelength,  $\lambda$ . At time  $t = 0$ , the leading Planck element P1 collides with the electron and scatters at an angle  $\theta$  with respect to the x-direction. The collision causes the electron to move by the amount with the x-component  $\Delta\lambda$ . P2 then arrives at the electron at  $t = \lambda'/c$  rather than  $t = \lambda/c$ . After scattering, P1 is followed by P2 with the  $\lambda'$  rather than  $\lambda$  distance apart. This is a geometric constraint for the change of the wavelength. We now need to express the x-velocity of the electron,  $u_{ex}$ , in terms of the properties of the incident and scattered waves. Referring to Fig. 4, the electron recoils by the distance with the x-component  $\Delta\lambda$  during the period of  $1/\nu_0$  seconds. The electron moves by  $(\lambda' - \lambda)$  every cycle of the incident wave, hence the total movement in one second by the electron must be  $\nu_0$  times  $(\lambda' - \lambda)$ .

Hence the x-velocity of the electron,  $u_{ex}$ , is

$$u_{ex} = \Delta\lambda \frac{\nu_0}{s} = \Delta\lambda \nu \quad (55)$$

or for every cycle the x-velocity increment is

$$\Delta u_{ex} = \frac{u_{ex}}{\nu_0} = \frac{\Delta\lambda}{s}. \quad (56)$$

The X-ray Planck elements impinge upon an electron in the positive x-direction and scatters in the direction  $\theta$ ,  $\theta$  being the angle of the scattered beam with respect to the positive x-direction. The wavelength of the primary beam (i.e., before the collision) is  $\lambda$  and that of the scattered beam (i.e., after the collision) is  $\lambda'$ . The apparent velocity of the Planck elements must be  $c$  both before and after the collision. By the classical two-body problem, the x-component of the momentum imparted to the electron by a Planck element that scatters at an angle  $\theta$  can be shown to be



$$P_{px} = M_p c . \quad (57)$$

The same Planck element after the collision with the electron has the momentum in the  $\theta$  direction

$$P_{p\theta} = M_p c . \quad (58)$$

Notice that the mass of the Planck element is unchanged and the effective speed of the Planck element is always the speed of light according to the EST. The conservation of momentum for the two-body problem in the x-direction requires

$$M_e \Delta u_{ex} = M_p c (1 - \cos \theta) . \quad (59)$$

With  $M_p = \frac{h}{c^2} \frac{1}{s}$ , from Eqs. (56) and (59) we then find

$$\Delta \lambda = \lambda' - \lambda = \frac{h}{M_e c} (1 - \cos \theta) . \quad (60)$$

Thus we see that the Compton scattering occurs as a result of the elastic collision between the X-ray Planck element and the moving electron. We have derived the Compton scattering equation by considering the geometric constraint of the Planck element and non-relativistic momentum conservation of the momenta of both this Planck element and the electron in the x-direction.

It is interesting to note that Compton compared the inelastic photon-electron collision problem with the classical Doppler effect - scattering of a ray by an electron moving in the direction of the incident ray. The classical Doppler principle provides the problem with exactly the same form of solution. The above solution is shown to hold as well when we consider the relativistic effect, for we can write Eqs. (56) and (59), respectively,

$$(\gamma \Delta u_e) \cos \varphi = \frac{u_{ex}}{v_0} = \frac{\Delta \lambda}{s} \quad (61)$$

and

$$(\gamma M_e \Delta u_e) \cos \varphi = M_p c (1 - \cos \theta) , \quad (62)$$

where

$$\gamma = \sqrt{\frac{1}{1 - \beta^2}}$$

and

$$\beta = \frac{u_e}{c} .$$

We now calculate the velocity of the electron after the collision by considering both the momentum and energy conservation. It is more convenient to write the momentum equation in the direction,  $\varphi$ , of the movement of the electron.

We note

$$\varphi = 90^\circ - \frac{\theta}{2}$$

for the collision that is elastic. The momentum conservation in this direction is given by

$$\gamma' M_e u_e' = \gamma M_e u_e + 2M_p c \cos \varphi \quad (63)$$

while the energy conservation is given by

$$\gamma' M_e c^2 = \gamma M_e c^2 + 2M_p c^2 \quad (64)$$

where

$$\gamma' = \sqrt{\frac{1}{1 + \beta'^2}} \quad (65)$$

and

$$\beta' = \frac{u_e'}{c}, \quad (66)$$

i.e.,  $\beta, \gamma$  are before the collision and  $\beta', \gamma'$  are after the collision. By using

$$M_p = M_e \frac{\alpha}{v_0} \quad (67)$$

where

$$v = \frac{v_0}{s},$$

we get

$$\beta' = \frac{\gamma\beta + \frac{2\alpha}{v_0} \sin \frac{\theta}{2}}{\gamma + \frac{2\alpha}{v_0}}. \quad (68)$$

For the EST model, the collision of a photon with the electron means repeating the collision of the Planck elements from  $P_1$  to  $P_{v_0}$  or in the above from  $\beta(1)=0$  to  $\beta(v_0)$ . Since  $v_0$  is a large number, for instance for an X-ray with  $\lambda=0.022\text{\AA}$ ,  $v_0 = 1.36 \times 10^{20}$ , the value to which  $\beta'$  converges, if it converges, would be the maximum value. To obtain the converged value of  $\beta$  or  $\beta_{\max}$ , we only need to let  $\beta' = \beta$  and solve the above. The result is

$$\beta_{\max} \approx \sin \frac{\theta}{2}, \quad (69)$$

hence

$$\beta_{\max} \approx 1 \text{ for } \theta = 2\pi.$$

If we treat the photon as a single particle, for elastic collision we only need to replace  $\alpha/v_0$  with  $\alpha$  and use the initial values  $\beta = 0$  and  $\gamma = 1$ , to obtain

$$\beta = \frac{2\alpha \sin \frac{\theta}{2}}{1 + 2\alpha} \quad (70)$$

For  $\lambda = 0.022\text{\AA}$ , this gives us

$$\beta_{\max} = 0.69 \text{ for } \theta = 2\pi.$$

This compares with the maximum velocity predicted by the inelastic single particles collision model,

$$\beta_{\max} = 0.82 \text{ for } \theta = 2\pi,$$

or the effective velocity deduced from the Doppler effect model

$$\beta_{\max} = 0.52 \text{ for } \theta = 2\pi,$$

both given by Compton [30].

Thus the single particles collision models predict the velocity of the electron to be no more than  $\beta_{\max} = 0.82$  while the present EST Planck element-electron collision model predicts it to be nearly the velocity of light. If we were to perform a single photon and a single electron collision and measure the speed of recoiling electron, and find the speed of the electron can be more than those predicted by the single particles model above, we would confirm the correctness of the EST model of photons.

## 5.2 The Wave Behavior of Light – Double Slit Interference

The vector potential waves shown in Fig. 1 are not observable quantities, but instead the Planck elements are. For these elemental waves, the constructive and destructive interference of the usual waves by the in-phase, out-of-phase additions of amplitudes is not possible. The presence of usual amplitudes, however, is not a necessary condition for interference patterns.

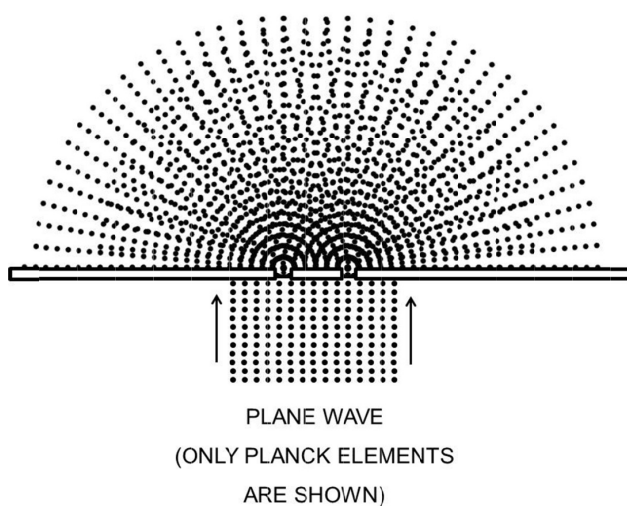

**FIG. 5** Illustration of the Double Slit Interference as Moiré Pattern (Not to Scale)

A Moiré interference pattern is not generally considered as true wave phenomenon, but it is how light visually manifests the interference behavior. A Moiré interference pattern appears when two grids of slightly different wavelengths and frequencies are overlaid in parallel or when two grids of the same wavelength and frequency are overlaid at an angle. Let us consider a double slit interference pattern of light. Fig. 5 shows a plane wave passing through a double slit.

The Planck element spherical waves emanating from the double slits form a Moiré interference pattern (on the detecting plate which is not shown) to manifest the observed double slit interference. For clarity of the interference pattern, only the Planck elements and no Gamma elements are shown.

The two grids need not be in place simultaneously to visually form a Moiré pattern. Since the human visual system holds onto one image for about one-fifteenth of a second, each of the grids only need to repeat more than 15 times per second for our naked eyes to see an interference pattern. The experiment by Tonomura, et. al. [31] showed single electrons passing through a double slits one electron at a time build up an interference pattern when recorded over time. This accumulated grid interference proves that a constructive or destructive amplitude superposition is not necessary for light to manifest wave behavior. It is consistent with the present elemental wave model.

## 6 THE UNCERTAINTY PRINCIPLE

To derive the uncertainty principle applicable to light, let us discretize the Planck constant:

$$h = h_0 kg \frac{m^2}{s^2} s = h_0 N_{kg} n_s \frac{c^2}{c_0^2} M_p t_p .$$

Thus we get,

$$M_p t_p = \frac{c_0^2}{h_0 N_{kg} n_s} \frac{h}{c^2} .$$

But  $t_p = l_p/c$ ,  $M_p = \frac{h_0}{c_0^2} kg$ , and  $N_{kg} = \frac{kg}{M_p} = \frac{c_0^2}{h_0}$ , hence we get,

$$n_s (M_p c) l_p = h .$$

By recognizing  $M_p c$  as the momentum of a Planck element, or  $P_p = M_p c$ , we then have

$$(n_s P_p) l_p = h . \quad (71)$$

Noting that  $n_s/s$  is equal to the frequency,  $\nu_\gamma$ , of the highest energy Gamma ray from which we deduced the Gamma elements, we recognize that  $n_s P_p = \nu_\gamma s P_p$  is the momentum of the highest energy Gamma ray photon. In general, one would try to measure the momentum and position of an event with a light ray having a frequency,  $\nu$ , and the photon momentum,  $P$ . Let the wavelength of this ray to be  $\lambda$ . By discretizing the wavelength,  $\lambda = n_\lambda l_p$  where  $n_\lambda$  is the number of the Gamma elements in the wavelength, and  $n_\lambda = n_s/(v s)$ , the above may be rewritten,

$$(v s P_p) (n_\lambda l_p) = h , \text{ or}$$

$$P \lambda = h , \quad (72)$$

in agreement with Eq. (29) which is a special case of Eq. (24). This is the same as the familiar equation for the uncertainty principle [32, 33],

$$\Delta P \cdot \Delta x = h , \quad (73)$$

where  $\Delta P$  and  $\Delta x$  are the uncertainties of the momentum and the position, respectively. They are identified as the momentum and the wavelength, respectively, of the photon of the light ray. Thus the present theory of the elemental space-time predicts the Heisenberg's uncertainty principle pertaining to light in its exact form. The interpretation is as follows. Referring to Figs. 1 & 2, if an observer fixes his observation location arbitrarily, a Planck element which is the light particle may be or may not be in that location. If he waits there, however, for a time, at most  $t = \lambda/c$ , the Planck element will emerge. Once the observer sees this Planck element, he can then predict where it will be in the next moment as a function of  $t_p$  and ultimately, the uncertainty will be within  $h/n_s$ , for we may rewrite Eq. (71) as

$$P_p l_p = h_p \quad (74)$$

where  $h_p = h/n_s$ . Instead of Eq. (73), we now have

$$\Delta P \cdot \Delta x = h_p . \quad (75)$$

hence one can predict the momentum of the Planck element and its location within the uncertainty of  $h_p$ . or with an almost certainty as  $h_p$  is such a small number compared to  $h$ . We will call this the time-discretized uncertainty principle or the EST uncertainty principle. Note  $h = h_o$  joule-sec, then  $h_p = h_o$  joule- $t_p$ , hence the measurement should be performed within the time duration  $t_p$  to obtain this accuracy.

Einstein's strong concern [9] on the quantum mechanics was that if the uncertainty principle and the statistical nature of the quantum mechanics is to become the foundation of the physics, "we must give up the hope and we shall never get any inside view of these important alterations in the single systems, in their structure and their causal connections" and by doing so "we must also give up, by principle, the space-time continuum." The EST model has answers to these concerns posed by Einstein. They are briefly: (1) space-time is now discrete in the units  $l_p$  and  $t_p$ , (2) we have the inside view of the uncertainty, and (3) yes, the uncertainty is still there because of the wave characteristic of light but only initially. Afterwards, the quantum states of light may be predicted within the reduced uncertainty as given by Eq. (75), which is to say almost with certainty because  $h_p$  is so much smaller than  $h$ , with the only uncertainty being within the discreteness of space-time.

## 7 THE COSMOLOGICAL CONSTANT

By 1920 several years after publishing his formulation of the general theory of relativity, Einstein addressed [34], "According to the general theory of relativity, space is endowed with physical qualities; in this sense, therefore, there exists an aether. According to the general theory of relativity space without aether is unthinkable; for in such space there not only would be no propagation of light, but also no possibility of existence for standards of space and time (measuring-rods and clocks), nor therefore any space-time intervals in the physical sense. But this aether may not be thought of as endowed with the quality characteristic of ponderable media, as consisting of parts which may be tracked through time. The idea of motion may not be applied to it." It is remarkable the characteristics of the Gamma element space described in this paper were predicted almost exactly by Einstein almost a century ago with regard to the general theory of relativity.

In the previous archive paper [35], the author presented a model for our Universe that convincingly suggested an equivalence of the dark energy, the cosmological constant of Einstein's general relativity [23, 36], and the Gamma elements of the present light model. By extracting from that paper [35], we write the stress energy tensor of the vacuum according to the general relativity as

$$T_{\mu\nu}^{(vac)} = -\frac{\Lambda c^4}{8\pi G} g_{\mu\nu} \quad (\mu, \nu = 0, 1, 2, 3), \quad (76)$$

where  $g_{\mu\nu}$  is the metric tensor, and  $\Lambda$  is the cosmological constant. The time-time component of the above is given by

$$\rho_{vac} \equiv \frac{\Lambda c^4}{8\pi G} \quad (77)$$

where  $\rho_{vac}$  is the vacuum energy density and have the same quality as the energy density of Gamma elements,  $\rho_\gamma c^2$ . ( $\rho_\gamma$  is defined as mass density.)

Hence by equating  $\rho_\gamma = \rho_{vac}/c^2$ , we get

$$\Lambda = \frac{8\pi G \rho_\gamma}{c^2} \quad (78)$$

where  $\Lambda$  has a dimension of  $[1/m^2]$ . In this way, we can establish the equivalence of the energy of Gamma elements and the energy of the cosmological constant even though they originate from very different motivations.

Now according to the measurements by NASA WMAP project [37, 38], only 4.6% of the Universe is due to the baryonic matter; the rest are approx. 23.3% due to cold dark matter and approx. 72.1% due to dark energy, or in terms of mass density,

$$\begin{aligned}\rho_{u0} \text{ (Universe)} &\approx 9.90 \times 10^{-27} \text{ kg/m}^3 \\ \rho_{a0} \text{ (observable matter-baryonic and all others)} &\approx 0.46 \times 10^{-27} \text{ kg/m}^3 \\ \rho_{dm} \text{ (dark matter)} &\approx 2.31 \times 10^{-27} \text{ kg/m}^3 \\ \rho_{de} \text{ (dark energy)} &\approx 7.14 \times 10^{-27} \text{ kg/m}^3.\end{aligned}$$

Similar results have been reported also by the Planck collaboration [39, 40]. Observable matter includes baryonic matter and radiation including the cosmic microwave background (CMB) radiation [41]. With the linear dimension of the Gamma element estimated in Section 3.1, the number of the Gamma elements in 1 m<sup>3</sup> volume is then calculated to be

$$N_\gamma = 1.00 \times 10^{57} - 1.00 \times 10^{75}$$

From this and the dark energy density, the mass of a Gamma element,  $M_\gamma$  is estimated to be

$$M_\gamma = \rho_{de}/N_\gamma = 7.14 \times 10^{-84} \text{ kg} - 7.14 \times 10^{-102} \text{ kg}.$$

This compares with the mass of a Planck element given by Eq. (6). The kinetic energy boost factor or the Lorentz factor for the Planck element from the Gamma element must then be

$$\gamma_p = M_p/M_\gamma = 1.03 \times 10^{33} - 1.03 \times 10^{51}.$$

Of course spins are not a linear motion and the Lorentz factor is not strictly applicable, but it indicates the average circumferential linear velocity caused by the spin motion is near the speed of light, as it should be to transmit the light energy at the speed of light. The correspondence between the presence of dark energy as observed, the presence of the cosmological constant in the general relativity, and the presence of the Gamma elements hypothesized by the present elemental space-time is remarkable.

It is known that all baryonic materials have spins. In particular, photons have spin one with the spin angular momentum,  $h$ , which is exactly the angular momentum of the Planck element. We are led to believe the Planck elements have spins but the Gamma elements have no spins. Light propagates through the Gamma elements which acquire the light energy by spinning. The supposed spin-zero property of the Gamma elements must have some correspondence with that of Higgs Boson [42-45] which is the only known particle to have zero spin, yet the latter occurs at a far greater energy and mass scale. The mass of a Higgs boson is reported to be approx. 126 GeV/c<sup>2</sup> or 2.25 x 10<sup>-25</sup> kg [46, 47] vs. estimated Gamma element 7.14 x 10<sup>-84</sup> kg - 7.14 x 10<sup>-102</sup> kg, a whopping discrepancy on the order of 10<sup>59</sup> - 10<sup>77</sup>. Thus, the Gamma element which has the characteristic of spin zero boson is not identified as the Higgs boson, the only spin zero boson experimentally confirmed to exist. A possible existence of alternate Higgs bosons is discussed in an author's companion paper [27].

## 8 SUMMARY AND CONCLUDING REMARKS

The EST model of the space-time brings the aether back, the primary motivation being to explain why the speed of light is constant in all inertial frames of reference and so only this time the aether is not absolute, but comprised of material elements having energy and corresponding mass. We call them Gamma elements. They transmit light and define the very concept of our time and distance. Time and distance are discretized, with  $l_p/t_p = c$ , the speed of light propagation, which explains why the speed of light is constant regardless of the frames of reference. An energized Gamma element is a Planck element having spin angular momentum defined by the Planck constant and their size is on the order of the wavelength of an assumed

cutoff, the highest energy  $\gamma$ -rays. A photon is now understood to be a single Gamma element vibrating or spinning with a frequency,  $\nu$ , or equivalently a series of Planck elements propagating at the phase velocity, the speed of light. The particle properties such as the photoelectric effect and Compton scattering, and the wave properties, such as diffractions, interference, and polarizations, are natural consequences of the EST model of light. The rest mass of the photon is  $M=hf/c^2$ . The uncertainty principle is another natural consequence of the EST model as a result of the wave behavior of light. After an initial uncertainty, however, the quantum state may be predicted to an almost certainty within the limit only restricted by the discreteness of the space-time. The EST model is shown to be consistent with the key experiments demonstrating wave-particle duality of light and to provide an inside view of the uncertainty principle. Planck elements are consistent with all electromagnetic and quantum field theory properties of photons. It may be said the Planck elements rather than the notional photons are the quantum of the electromagnetic field.

Along the lines of Feynman and Wilczek quoted in Section 1, the following may be said with regard to light.

The Gamma element space is an electromagnetic field that can carry the light energy as waves, but also effectively like particles, and that the quantum mechanics unifies the idea of the field and its waves, and the particles all into one, albeit the definition of the waves and particles must be more inclusive, the uncertainty principle may be refined, and the probability density distribution of the quantum wave equation may be reinterpreted as the real distribution of Planck elements. The Gamma element space fulfills the vision of the primary ingredient, the “grid,” that fills our space and time, is alive with quantum activity with almost certainty, contains material components, gives space-time rigidity, and weighs.

Note that the gravity is omitted from the statement: whether the Gamma elements are the cause of gravity or medium of gravitational field must be investigated in the future, but we have conjectured an equivalence of the dark energy, the cosmological constant of Einstein’s general relativity, and the Gamma elements of the present space-time model for light.

We have introduced some new terms; elemental space-time, EST principle, Gamma element, Planck element, discretizing, and elemental space-time waves, etc. for the present theory. The term “Gamma element” emphasizes the discrete nature of the specific material filling our space. The term “Planck element” distinguishes itself from the “Planck particle” which refers to the notional particle associated with the conventional Planck units.

**Acknowledgments** The author dedicates this work to late professor emeritus H. Kolsky of Brown University for guiding him to the field of stress waves in solids. The interest led him to the present subject long after his decease. Any deficiency of this paper, therefore, is the fault of the author.

## References

1. Griffiths, D.: *Introduction to Elementary Particles, Second, Revised Edition*, Wiley-VCH Verlag GmbH & Co. KGaA, Weinheim, 3<sup>rd</sup> print (2010)
2. Peskin, M. and Schroeder, D.: *An Introduction to Quantum Field Theory*, Westview Press. ISBN 0-201-50397-2 (1995)
3. Itzykson, C. and Zuber, J.: *Quantum Field Theory*, Dover edition (2005), copyright by McGraw-Hill, Inc., New York (1980)
4. Michelson, Albert A.; Morley, Edward W. (1887). "On the Relative Motion of the Earth and the Luminiferous Ether". *American Journal of Science* **34**: 333–345. doi:10.2475/ajs.s3-34.203.333.

5. Einstein, A.: On the Electrodynamics of Moving Bodies, English translation of the original 1905 German-language paper (published as Zur Elektrodynamik bewegter Körper, in *Annalen der Physik*. 17:891, 1905) in *The Principle of Relativity*, Methuen and Company, Ltd. of London, (1923).
6. Feynman, R. P.: *Feynman's Lectures on Physics, Volume 1, Chapter 2*. Caltech. (1963).
7. Wilczek, F.: *The Lightness of Being, Chapter 8*, Basic Books (2008).
8. [https://en.wikipedia.org/wiki/Aether\\_theories](https://en.wikipedia.org/wiki/Aether_theories)
9. Einstein, Albert: Physics and Reality, *Journal of the Franklin Institute*, vol. 221, p. 349-382 (03/1936) DOI:10.1016/S0016-0032(36)91047-5 Bibliographic Code:1936FrInJ.221..349E.
10. [http://imagine.gsfc.nasa.gov/docs/ask\\_astro/answers/970412e.html](http://imagine.gsfc.nasa.gov/docs/ask_astro/answers/970412e.html), Ask an Astrophysicist: Is there an upper limit to the Electromagnetic Spectrum?
11. *Aharonian, Felix (24 August 2010). "The Fascinating TeV Sky" (PDF). WSPC - Proceedings. Retrieved 27 November 2011.*
12. Einstein, A.: On a Heuristic Point of View about the Creation and Conversion of Light, in *The Old Quantum Theory*, Pergamon Press, pp. 91–107 (1967).
13. Wikipedia, the free encyclopedia, [http://en.wikipedia.org/wiki/Louis\\_de\\_Broglie](http://en.wikipedia.org/wiki/Louis_de_Broglie) (2013).
14. Wikipedia, the free encyclopedia, [http://en.wikipedia.org/wiki/Ultra-high-energy\\_gamma\\_ray](http://en.wikipedia.org/wiki/Ultra-high-energy_gamma_ray) (2014).
15. *Aharonian, F. et al, The time averaged TeV energy spectrum of Mkn 501 of the extraordinary 1997 outburst as measured with the stereoscopic Cherenkov telescope system of HEGRA, arXiv:astro-ph/9903386v2 (Jul 1999).*
16. H.E.S.S. Collaboration, A. Abramowski, et al., *HESS J1640-465 - an exceptionally luminous TeV gamma-ray supernova remnant, arXiv:1401.4388v2 [astro-ph.HE] (Feb 2014).*
17. Stecker, F.W.: *Exploring the ultrahigh energy neutrino universe*, arXiv:astro-ph/0003459 30 (Mar 2000).
18. Stecker, F.W.: *The curious adventure of the ultrahigh energy cosmic rays*, arXiv:astro-ph/0101072 v2 11 Jan 2001.
19. Wikipedia, the free encyclopedia, [http://en.wikipedia.org/wiki/Planck\\_particle](http://en.wikipedia.org/wiki/Planck_particle), Dec. 2011.
20. Min, Brian B.K.: Physics of Elemental Space-Time – A Theoretical Basis For the New “Planck Element” Scale <http://vixra.org/pdf/1504.0137v1.pdf> (2015)
21. Aharoni, J.: *The Special Theory of Relativity*, Oxford University Press (1965).
22. Min, Brian B.K.: A Relativistic Quantum Wave Equation That Reduces to the Schrödinger Equation in the Non-Relativistic Limit, <http://vixra.org/pdf/1504.0135v1.pdf> (2015)
23. Einstein, A.: *Relativity: The Special and General Theory*; translated by Robert W. Lawson and originally published by H. Holt, New York, 1920; Dover Publications, Section XV, p. 52 (2001)
24. Born, M.: *Einstein's Theory of Relativity*, Dover Publications (1965).
25. Okun, L. B.: *The Concept of Mass*, *Phys. Today*, p.31, June (1989).
26. de Broglie, L.: doctoral thesis of 1924, *Recherches sur la theorie des quanta* (*Ann. de Phys.*, 10e s'erie, t. III (Janvier-Février 1925). A translation by: Kracklauer A. F. (2004) [http://aflb.ensmp.fr/LDB-oeuvres/De\\_Broglie\\_Kracklauer.pdf](http://aflb.ensmp.fr/LDB-oeuvres/De_Broglie_Kracklauer.pdf)
27. Min, Brian B.K.: *Transforming Between Massive and Massless States for Bosons by Spontaneous Breakdown of Symmetry in an Alternate Klein-Gordon and Alternate Higgs Fields*, <http://vixra.org/pdf/1602.0375v1.pdf> (2016)
28. Kolsky, H.: *Stress Waves in Solids*, Dover Publications (1963).
29. *Achenbach, J.D. Wave Propagation in Elastic Solids, North Holland Publishing Co./American Elsevier Publishing Co., 1975*
30. Compton, A.H.: *A Quantum Theory of the Scattering of X-Rays by Light Elements*, *The Phys. Rev.*, Second Series, **21**, No.5, p. 483 (1923)
31. Tonomura A., Endo J., Matsuda T., Kawasaki T., & Ezawa, H.: *Am. J. Phys.* **57**, 117–120 (1989). Also <http://www.hitachi.com/rd/research/em/doubleslit.html>
32. Heisenberg, W. (1930), *Physikalische Prinzipien der Quantentheorie (in German)*, Leipzig: Hirzel English translation *The Physical Principles of Quantum Theory*. Chicago: University of Chicago Press, (1930).
33. Weinberg, S.: *Lectures on Quantum Mechanics*, Cambridge University Press, New York (2013)
34. Einstein, A.: *Ether and the Theory of Relativity*, An Address delivered on May 5th, 1920, in the University of Leyden, Sidelights on Relativity, pp. 3-24, London: Methuen, translated by George Barker Jeffery and Wilfrid Perrett (1922)
35. Min, Brian B.K.: Physics of Elemental Space-Time and Cosmology, <http://vixra.org/pdf/1504.0136v1.pdf> (2015)
36. [https://en.wikipedia.org/wiki/Cosmological\\_constant](https://en.wikipedia.org/wiki/Cosmological_constant)



37. NASA, <http://map.gsfc.nasa.gov/universe>, Wilkinson Microwave Anisotropy Probe (WMAP) (2011).
38. Bennett, C. L. et al.: *Nine-Year Wilkinson Microwave Anisotropy Probe (WMAP) Observations: Final Maps and Results*, arXiv:1212.5225v3 (2013)
39. Wikipedia, the free encyclopedia, [http://en.wikipedia.org/wiki/Planck\\_\(spacecraft\)](http://en.wikipedia.org/wiki/Planck_(spacecraft)) (2014)
40. Planck Collaboration, *Planck 2013 results. XVI. Cosmological parameters*, arXiv:1303.5076 [astro-ph.CO] (2013).
41. Fukugima, M. & Peebles, P. J. E.: *The Cosmic Energy Inventory*, arXiv:astro-ph/0406095v2, (2004)
42. Wikipedia, the free encyclopedia, [http://en.wikipedia.org/wiki/Higgs\\_boson](http://en.wikipedia.org/wiki/Higgs_boson) (2014)
43. Englert, F. and Brout, R.: *Broken Symmetry and the Mass of Gauge Vector Mesons*, Physical Review Letters 13 (9): 321–323. Bibcode 1964PhRvL..13..321E. doi:10.1103/PhysRevLett.13.321. (1964)
44. Higgs, P. W.: *Broken Symmetries and the Masses of Gauge Bosons.*, Physical Review Letters 13 (16): 508–509. Bibcode 1964PhRvL..13..508H. doi:10.1103/PhysRevLett.13.508. (1964).
45. Guralnik, G. S., Hagen, C. R. and Kibble, T. W. B.: *Global Conservation Laws and Massless Particles*, Physical Review Letters 13 (20): 585–587. Bibcode 1964PhRvL..13..585G. doi:10.1103/PhysRevLett.13.585. (1964).
46. The ATLAS Collaboration, *Observation of a new particle in the search for the Standard Model Higgs boson with the ATLAS detector at the LHC*, arXiv:1207.7214v2 (Aug 2012)
47. The CMS Collaboration, *Observation of a new boson at a mass of 125 GeV with the CMS experiment at the LHC*, arXiv:1207.7235v2 (Jan 2013)
48. Einstein, A.: *Ether and the Theory of Relativity*, An Address delivered on May 5th, 1920, in the University of Leyden, Sidelights on Relativity, pp. 3-24, London: Methuen, translated by George Barker Jeffery and Wilfrid Perrett (1922)