

A Method for Calculating Orbital Velocities in Expanding or Contracting Space-Time.

By John S. Huenefeld

ABSTRACT

We are told that as expansion of the universe continues to accelerate, stars will eventually be ripped from galaxies, then planets will be ripped from their stars. Eventually the planets themselves will be torn apart by the force of expanding space-time and then even molecules and atoms. When asked at what specific expansion rates these things will happen, no one has an answer.

Galaxy models used to estimate the amount of dark matter required to explain observed rotation rates do not account for universal expansion in the calculations, as if expansion is not happening within galaxies at all. The consensus is that expansion is very small, and is easily overcome by local forces. This may be true on Earth, or in our solar system, but galaxies are very large, and orbits in galaxies take place in a realm of very small accelerations acting over very large distances. Within a galaxy the size of the Milky Way, outward drift due to expansion may exceed inward fall due to gravity, on a per second basis, by up to thirteen orders of magnitude.

It is difficult to imagine how gravity overcomes these relatively large expansion rates and calls into question the correctness of ignoring universal expansion in galaxy models. If ignoring expansion is correct, then does it mean that universal expansion does not actually happen within galaxies? And if not, why not? Why do we see red shift in the light from distant galaxies, clearly a sign of an expanding universe, and yet see no evidence of expansion going on locally in the solar system or within our galaxy?

If a method for calculating the orbital velocities of gravitationally bound objects including the effect of expansion (or contraction) of space-time could be developed, these questions will have definitive answers. That is the object of this paper.

SECTION 1. The Galactic Gravitation Environment.

A galaxy the size of the Milky Way is around 30,000 parsecs or greater in diameter and may have a mass of over 500 billion suns (including all types of matter). Orbital velocities of over 250,000 meters per second are observed right out to the rim. Amidst all these very large numbers, the accelerations due to gravity are actually very small. At 9,000 parsecs from the center (where our sun would be) the acceleration is around $2.7e-10$ meters per second. At the rim, accelerations drop to $1.35e-10$ meters per second. Thus stars occupy very long lazy orbits taking hundreds of millions of years to complete.

Given that we see stars at the rims of galaxies orbiting a 250,000 meters per second, we may expect with great confidence that an object released at the rim of

the galaxy, at rest with respect to the galactic center, will fall slowly inward. If however, we apply a Hubble expansion rate of 73.2 km/s/Mega parsec to the 15,000 parsec radius at the rim, space-time at the rim will be expanding outward at around 1,100 meters per second. For an object to fall 1,100 meters at an acceleration of 1.35×10^{-10} meters per second would take over 500,000 years. In that amount of time the object will have been carried 1.9 light years outward from its starting point. It might seem there is no way gravity, even with dark matter, can compete with that rate of expansion, but galaxies work on vast time scales and half a million years is small fraction of star's orbit.

One might argue that stars have an intrinsic inward velocity toward the galactic center that negates expansion. But after a quarter orbit, that velocity vector would be parallel to the orbital path and after a half orbit it would be directed away from the galactic center. Unless the inward intrinsic velocity vector somehow rotates with the orbit, expansion would noticeably elongate gravitational orbits of stars within galaxies. Then again, seeing a star in an elongated orbit would be no surprise at all.

SECTION 2. Circular Orbits.

Given that we observe objects in stable orbits, and that universal expansion is well accepted, we may thus suppose that stable orbits are possible in expanding space-time. Let's begin with the simple case of a circular orbit and assume an object is in a stable gravitational orbit around a body of mass M at a radius R in an expanding or contracting space time. By stable orbit, it is meant that the object has gone around many times and all transient effects have vanished. The object follows the trace of the circle at the same radius and velocity over and over again.

Next, in order to visualize what is happening with space-time as it expands or contracts, lets imagine a new sort of material, inventing it akin to the way dark matter was conjured up. Unlike dark matter, which does not interact with light (other than through gravitational lensing) but does interact with gravity, this new material will interact with light but will not interact with gravity. Let's call it "light matter." Light matter would be a perfect "dye marker" to paint onto the fabric of space-time. It will be visible but unaffected by gravity so it will drift along with the reference frame into which it is placed.

If a ring of light matter dust is sprinkled along the circular path of the orbiting object, it will act as glitter embedded in the fabric of space-time, and it will mark the path of the orbit in flat space-time. In expanding space-time it will mark the path of the orbit as space-time expands, as shown in figure 1. Over the course of an orbit, the ring of light matter dust will expand or contract by a distance equal to the expansion / contraction velocity at R times the period of the orbit.

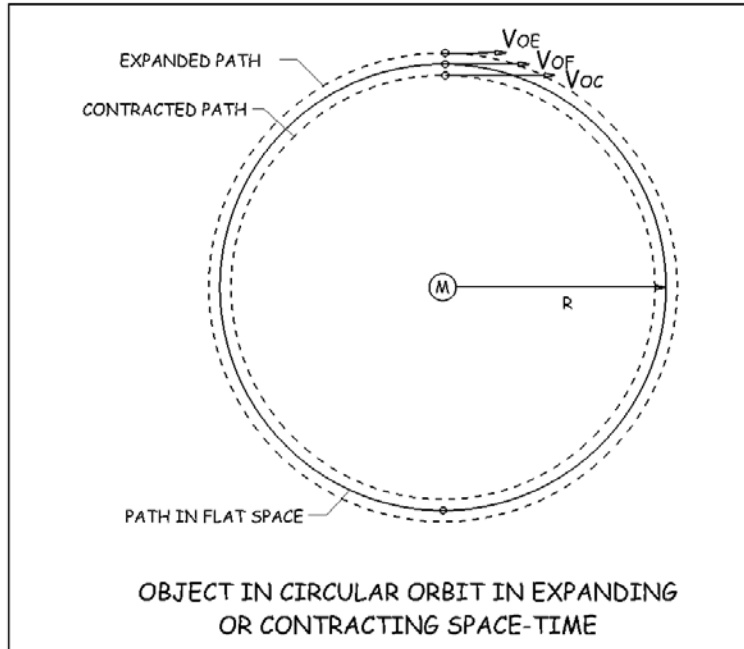

Figure 1.

In this thought experiment, both gravity and expansion act along the radial line between the central mass and the orbiting object, and the radial line is always perpendicular to the velocity vector of the orbiting object. As it orbits, the object will experience a perpendicular “space-time crosswind”, thus it will be swept either outward by expansion or inward by contraction over the course of the orbit.

The object however, must follow the original circle, this keeps the radius and gravitational acceleration from the central mass constant. Since the expansion or contraction velocity (**drift velocity**) is also a function of radius, it remains constant as well. The only variable allowed to change is the orbital velocity. In expanding space-time, the object must orbit at a lower velocity, allowing it to fall back inward due to gravity by a distance equal to the distance it will be swept outward by expansion. In contracting space-time, the object must orbit at a higher velocity, allowing it to rise outward against gravity by a distance equal to the distance it will be swept inward by contraction.

To better illustrate how this works, spirals of light matter have been placed onto the fabric of space-time in figure 2, leading both inward and outward from the orbiting object. These spirals have been carefully placed so that as the object orbits, the spirals are expanded or contracted keeping the crossing point with the circle coincident with the center of the satellite. The inward spiral represents the path of the satellite in expanding space, showing how it must continuously fall inward at the drift velocity as it circles the central mass. The outward spiral represents the path of the satellite in contracting space, showing how it must continuously rise outward as it circles the central mass.

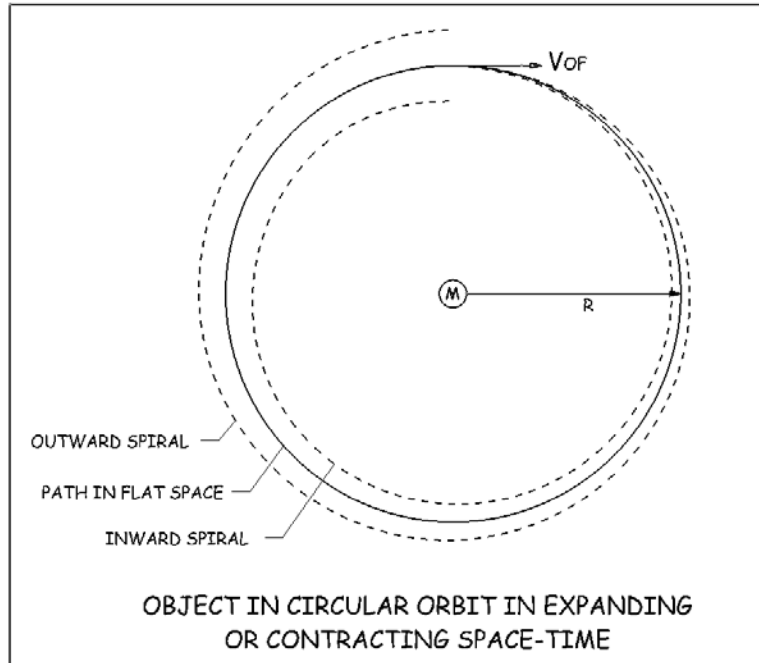

Figure 2.

To find the change in orbital velocity required, we begin by calculating the distance s that the object will be swept inward or outward over an arbitrary time interval Δt . For expanding or contracting space-time, the rate (velocity) of expansion or contraction is usually expressed as a function of radius R . Any function may be used because in the case of circular orbits R is constant. Expansion is generally expressed as increasing linearly with R . The term H is used to indicate Hubble expansion. Rather than using $-H$, I will use capital C to indicate contraction.

$$\begin{aligned} \text{expansion velocity } v_E &= HR \\ \text{contraction velocity } v_C &= CR \\ \text{distance } s &= HR\Delta t \text{ or } s = CR\Delta t \end{aligned}$$

The distance s will be equal to either HR times Δt or CR times Δt . Having established the distance s , one might think it a simple matter of either increasing or decreasing the centripetal acceleration by an amount just enough to equal the same distance s over the same Δt . Difficulties arise, however, with this method because on one hand s is proportional to Δt and on the other, for acceleration, it is proportional to Δt squared. Thus for very short values of Δt , expansion is much more influential, and for very long values of Δt , acceleration becomes dominant.

In an attempt to avoid the apples to oranges mix of velocity and acceleration, my approach is to calculate the displacement distance s for each separately and

then add the results. The total displacement distance s is equal to the contribution due to gravity plus the contribution due to contraction or expansion.

$$S_{total} = S_{gravity} \pm S_{expansion}$$

To derive a formula for an orbital velocity in contracting space-time, I will use Newton's method of equivalent triangles [1] as he applied it to the orbit of the moon in 1666. As shown in figure 3, as an object moves around a circular path from point A to point B it will be swept toward the central mass M by distance S while translating perpendicular to S by a distance X. By the law of equivalent triangles, as shown above, distance S is to distance X, as distance X is to distance 2R minus S.

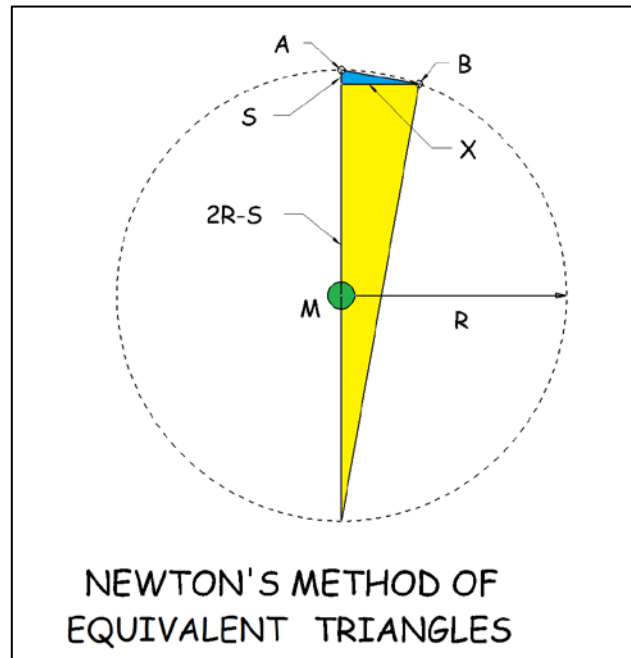

Figure 3.

Newton's derivation of the velocity for a gravitational circular orbit in flat space-time follows. Where G is the gravitational constant and M is the mass of the central body.

$$\frac{s}{x} = \frac{x}{2R - s} \quad \text{or} \quad x^2 = (2R - s)s$$

When $R \gg S$ $(2R - S) \approx 2R$ and thus $x^2 \approx 2Rs$

$$x^2 = 2Rs \quad \text{or} \quad x = \sqrt{2Rs}$$

$$\text{Orbital Velocity} = x/\Delta t = \sqrt{2Rs/\Delta t^2}$$

$$\text{using } S = \frac{a\Delta t^2}{2} \text{ and acceleration } a = \frac{GM}{R^2}$$

$$\text{Thus } V_{orbit} = \sqrt{GM/R}$$

$$\text{Orbital velocity in flat space: } v_{og} = \sqrt{GM/R} \text{ or } v_{og} = \sqrt{aR}$$

To adjust the orbit velocity for the effect of contraction or expansion of space-time, the amount of expansion or contraction that happens over delta t is subtracted from, or added to the value of s, as shown in Figure 4.

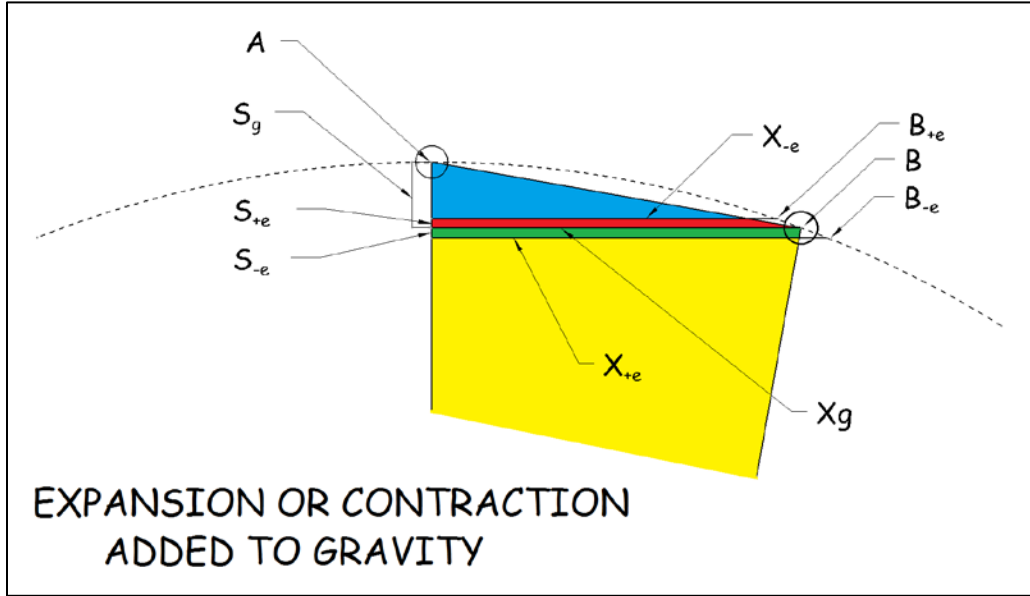

Figure 4

$$s_e = \pm HR\Delta t = \pm V_{Drift}\Delta t \text{ and } s_g = \frac{a\Delta t^2}{2} \text{ and } x = \sqrt{2R(s_g + s_e)}$$

Doing the algebra we get.

$$v_{oe} = \frac{x}{\Delta t} = \sqrt{\frac{2Rs_g}{\Delta t^2} \pm \frac{2Rs_e}{\Delta t^2}} = \sqrt{aR \left(1 \pm \frac{2V_{Drift}}{a\Delta t} \right)}$$

The result is an expression for orbital velocity where the acceleration of gravity is multiplied by a dimensionless scale factor. Let's see how this works for the planets in our solar system using NASA's latest value for the expansion of the universe.

The velocity required to orbit in space-time expanding at H will be computed by subtracting the distance space-time will expand over delta t from the distance the

orbiting body would fall due to gravity over the same delta t. The value of H used in the calculations is from NASA [2] and appears below*.

$$H = 73.2 \text{ Km/s per Mega parsec, or } 2.37223 \times 10^{-18} \text{ s}^{-1}.$$

(*H may have been updated since the writing of this paper.)

Planet or Object	Orbit Diameter in meters (circular orbit is assumed)	Observed Period T in seconds	Calculated Velocity by $(\pi * D)/T$ m/s	Velocity Predicted by Newton m/s	Orbital Velocity from H m/s	Corrected Orbital Velocity for H m/s
Mercury	115,800,000,000.00	7,603,200	47847.805	47867.531	-0.166	47867.365
Venus m	216,400,000,000.00	19,414,080	35017.917	35016.012	-0.793	35015.219
Earth	299,200,000,000.00	31,558,464	29784.863	29779.302	-1.783	29777.519
Mars	455,800,000,000.00	59,356,800	24124.244	24127.268	-5.107	24122.161
Jupiter	1,557,000,000,000.00	375,545,721	13024.938	13054.222	-110.603	12943.619
Saturn	2,853,000,000,000.00	930,974,688	9627.505	9643.716	-514.273	9129.443
Uranus	5,742,000,000,000.00	2,650,910,976	6804.840	6797.727	-4132.740	2664.987
Neptune	8,997,000,000,000.00	5,200,834,867	5434.687	5430.583	-5772.213	-337.526
Kuiper Belt (100 AU)	14,959,787,000,000.00			4211.459	-12616.6	-8105.141
Oort Cloud (300 AU)	44,325,294,814,814.80			2446.637	-45889.5	-43442.863

Table 1. Delta t equals 1 second.

Table 1 shows the values of orbital diameters and periods observed for the planets and orbital velocities calculated based on Newtonian gravity, assuming circular orbits. The last two columns show reductions in orbital velocities calculated for space-time expansion at the currently observed H and that value subtracted from the velocity of the gravitational orbit. The effect of expansion on the inner planets is small but becomes increasingly significant with increasing radius R from the sun. The equation blows up at the orbit of Neptune. Values shown for Neptune and beyond were calculated using contraction (to keep the term under the radical positive) and then applied in reverse.

The conventional wisdom is that universal expansion is too small to have any effect on the orbits of bodies within our solar system. Based on this method, the results show that if expansion is going on in our solar system, the sun would not be able to retain any object beyond the orbit of Uranus. In fact, Uranus would barely orbit at all, hovering nearly motionless at the edge of the solar system.

Initial reactions will likely be that there is either something wrong with the method or with the calculations. Newton used the method of similar triangles to check his gravitational equation, and it may also be used to derive the formula for gravitational orbital velocity used above.

The use of a delta t of one second may be questionable. As the equation for orbital velocity under expansion stands above, there is a dependency on the value of delta t chosen. There ought to be a single answer for orbital velocity independent of the time period used. On one hand, if a very long time period is used, the effect of expansion will vanish (making life easy for cosmologists). On the other hand, if one were setting up a computer simulation, it would be tempting to use a very short time step to improve accuracy, but in that case it would be gravity that vanishes. For Newton's method to work, the time period must be some fraction of the orbital period. That rules out very long time periods that make the problem of expansion vanish. What we need is a time period that balances the second order term with the first order term.

Two possible approaches could be taken to resolve the issue. First, another mathematical relationship could be sought to identify the proper value of delta t, and second, a value of delta t could be chosen to match observations. In a Fluid Space Theory [3] model of the galaxy and the solar system, the value for delta t which best matches observations for contraction fields is e seconds or 2.71828. This is also reasonable from a mathematical standpoint as e is the natural balancing point for terms of different orders.

$$v_{oe} = \sqrt{aR(1 \pm \frac{2V_{Drift}}{aet})} \text{ where } t \text{ is 1 time unit.}$$

After checking the method and the calculations, even using time units multiplied by e, the current value of H will still strip away anything orbiting our sun beyond Uranus. It is even worse for our galaxy, ripping it apart even with the assumption of vast amounts of dark matter. The conclusion is that universal expansion is not happening within our solar system and is certainly not happening within our galaxy. Therefore, it is correct to ignore universal expansion in the computation of orbits within the galaxy. But why? The fact that we see stars orbiting within galaxies at higher velocities than predicted by Newton may be an indication that space-time contraction is going on within galaxies instead [3].

References

- [1] Isaac Newton – 1666, method of equivalent triangles for orbital velocity.
- [2] NASA – https://wmap.gsfc.nasa.gov/universe/uni_expansion.html.
- [3] Huenefeld, J. S. – 2018, <http://vixra.org/abs/1807.0342>.