

## Abstract

The model of this paper states that space-time is another state of matter, and that matter and space-time are composed of identical quantized physical units whose constituent sub-structures are composed of D-branes and Type I strings. The quantum structure of space-time and matter is designated the D-string. The D-strings of matter and space-time differ from one another only in the volumetric state of the D-string. The D-string model presupposes that the universe is composed solely of a finite number of D-strings with physical properties that are quantized with finite limits of range, and are responsible for all physical phenomena. The relationship of the D-string to Planck's natural constants, gravity, time dilation, and the observed constancy of the speed of light are specifically addressed; a mathematical argument is presented demonstrating the conversion of space-time into matter.

## A Model of Space-time as an 11-dimensional State of Matter

Gary Heen

grhdsh@gmail.com

### 1. Introduction

Modern theory states that matter and energy in their most basic form exist in discrete amounts, or quanta. The author proffers that space-time also exists as discrete quanta, and derives a physical model of space-time and elemental particles of matter. The hypothesis for this model is that the quanta for matter and space-time are convertible states of the same hidden variable elementary building blocks composed of D-branes and Type I strings: the D-string.

### 2. D-string Structure

The structure of the D-string is determined by a specific orientation and attachment of D-branes and Type I Strings to one another forming the physical D-string quantum.

#### 2.1 Relating Type I strings and D-branes to D-string Structure

Planck's length [<sup>1</sup>] and Planck's time [<sup>2</sup>] quantify two of the physical parameters of the D-string. The maximally expanded D-string is a cubic hexahedron, with the length along any side equal to Planck's length ( $l_p$ ), see figure 1(A). Each individual expansion or contraction of a D-string occurs in a quantum jump, and the time interval from initiation to completion of a

quantum jump is equal to Planck's time and is invariant. After the first and any subsequent quantum jump contractions of the D-string, the cubic shape of the D-string distorts along multiple axes but maintains hexahedral shape with six planar faces, see figure 1(B). The range between maximally expanded and maximally contracted states of a D-string defines space-time curvature.

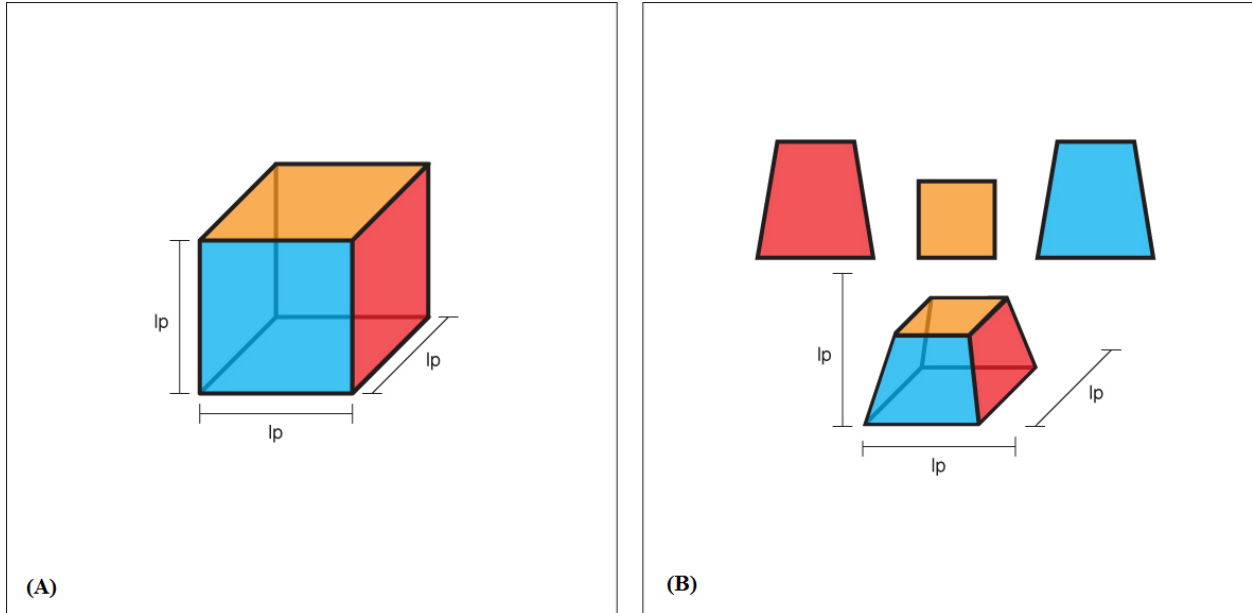

**Figure 1.** (A) D-string fully expanded, with each facet equaling Planck's length (B) D-string in a partially contracted state, with facet lengths less than Planck's length.

D-branes were discovered independently by Petr Horava, [3] and by the team of Jim Dai, Rob Leigh, and Joe Polchinski. [4] The D-brane is named after 19th century mathematician Johann Peter Gustav Dirichlet [5]. Dirichlet's boundary conditions [6] are a set of restraints in that the Type I string ends are fixed in position, i.e. both ends of the Type I strings are attached to D-branes.

## 2.2 D-string model postulates:

1. The D-string is composed of Type I strings and D-branes, and that matter and space-time are different volumetric states of the D-string, and are convertible into one another. A fully contracted D-string is a quantum particle of matter, and an expanded D-string is a unit of quantized space-time.
2. D-branes occupy the surface of the six facets of the hexahedral D-string.
3. The Type I strings are within the D-string and attach from one facet D-brane across to the opposing parallel facet D-brane, see figure 2(A).

4. The string attachment pattern of the two facets of an axis of a D-string is a unique stereoisomeric configuration with respect to that axis, resulting in space-time and matter having chirality, see figure 2(B).
5. The opposing D-branes of the x, y, and z-axes are mirror image nonsuperposable enantiomers.
6. All D-strings have identical numbers and types of strings and D-branes.
7. It is known that D-branes possess charge, [7] but additionally in this model the mirror image D-branes of a D-string carry equal and opposite charges.
8. Mirror image D-branes align to match Type I string configurations of abutting D-strings and bond to one another by attraction of opposite charges.
9. D-strings spontaneously expand but can never spontaneously contract, and the interval from initiation to completion of an expansion or contraction of a D-string occurs in one Planck's time interval. In one unit of Plack's time?
10. The level of contraction, or decrease in volumetric state of a D-string from the maximally expanded state, is termed the quantum level of spatial contraction (QL) of a D-string. All D-strings undergo expansion and contraction in discrete steps, known as quantum jumps.
11. D-strings will spontaneously expand in quantum jumps to approach a maximally expanded state.
12. String lengths within a D-string equilibrate to approach or attain identical lengths when a D-string undergoes an initial geometric change along any axis.
13. Abutting D-strings with unequal contracted states will interact in quantum jumps to approach or attain equal levels of contraction.
14. Potential energy of a D-string is proportional to the level of the contracted state of the D-string; the greater the contracted state, the greater the potential energy. Particle matter, being fully contracted D-strings, has a higher potential energy state than any space-time D-string.
15. Kinetic energy of space-time is the geometric changes or vibrations of D-branes and Type I strings of a D-string. Sounds like 'energy is the changes'... sounds odd. Restate?

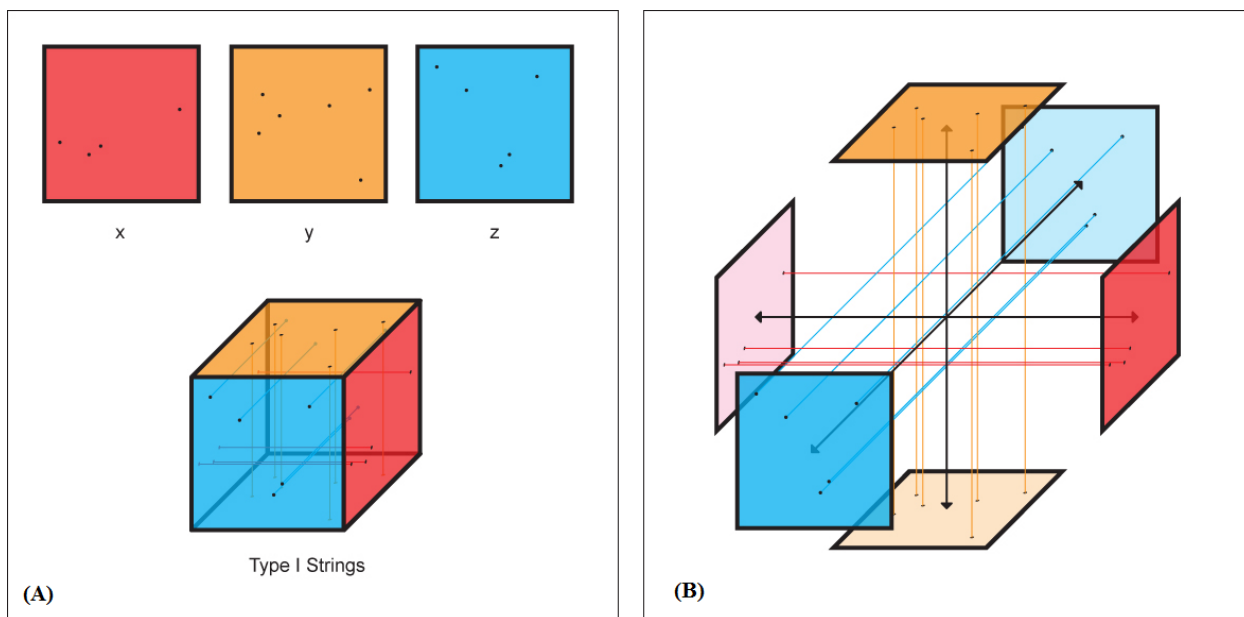

**Figure 2.** (A) Colored facets represent D-branes. (B) D-string exploded view, colored lines represent Type I strings.

### 2.3 The 10-dimensional and 11-dimensional Duality of the D-string

The one-dimensional Type I strings constitute the three dimensions of the x, y, and z-axes. The author proffers that each of the D-branes occupying the six facets of the D-string are mathematically interpreted as distinct higher dimensions due to their attachment to the Type I string dimensions and the unique stereochemistry of each of the two-dimensional D-brane sheets. The six D-branes on the D-string facets are arbitrarily named top, bottom, left, right, front, and back. The nomenclature of the 2-brane will be used to distinguish the higher dimensionality of the D-brane. The 10 dimensions of the D-string are:

- |                          |                  |
|--------------------------|------------------|
| 1. x-axis Type I strings | 6. left D-brane  |
| 2. y-axis Type I strings | 7. right D-brane |
| 3. z-axis Type I strings | 8. front D-brane |
| 4. top D-brane           | 9. back D-brane  |
| 5. bottom D-brane        | 10. time         |

Minkowski first proposed the linking of space and time as space-time. [8] In this paper, time is defined as the interval from initiation to completion of a geometric change in a quantum of space-time. Restated, since space and time are inexorably linked as the one entity of space-time, a change in one component of space-time necessarily causes a change in the other; therefore, a change in the geometry of an expanded D-string (space) is required for change in time to occur.

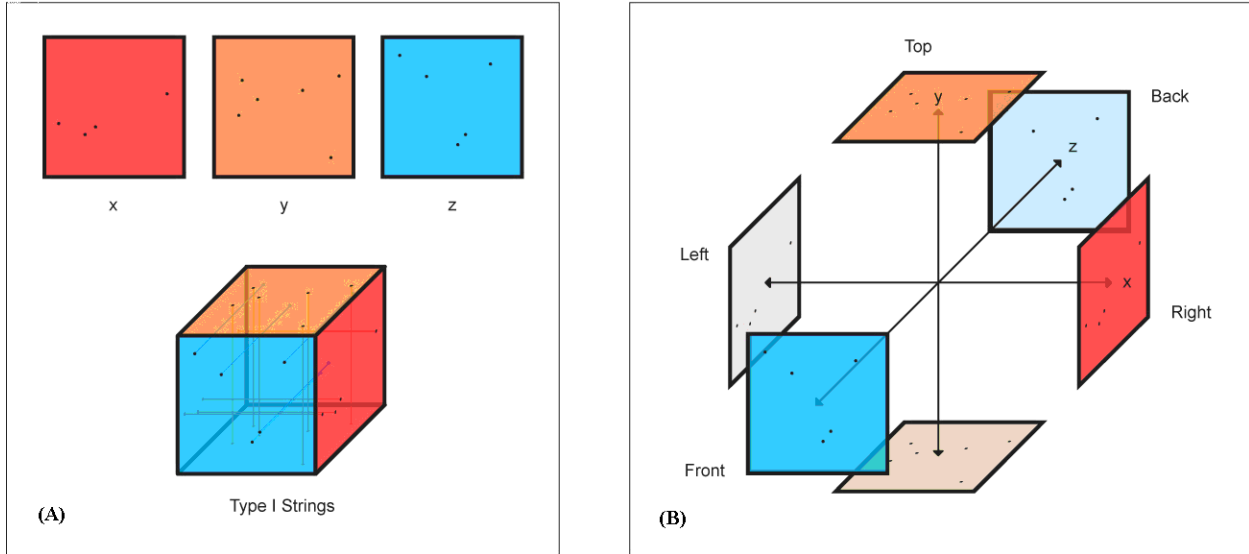

**Figure 3 - The 10-dimensional D-string**

The dimensionality of the D-string can also be considered 11-dimensional by presuming the following progression of dimensionality:

- (1) The linear one-dimensional Type I strings are one level of dimensionality, i.e. 1-brane.
- (2) The two-dimensional D-brane sheets are a secondary higher level of dimensionality, i.e. 2-brane.
- (3) Then, a three-dimensional configuration of all six D-branes of a D-string projecting into space simultaneously can be considered a third higher level of dimensionality, i.e. 3-brane.

Therefore, the addition of a 3-brane dimension to the ten dimensions previously outlined results in an eleven dimensional D-string. Both ten and eleven-dimensional models express the same concept of the D-string in different ways, i.e. the models are a duality. The equivalency or duality of 10-dimensional and 11-dimensional string theory has been shown mathematically. [9][10]

Generally, D-branes are associated with quantum chromodynamics (QCD), and strings are associated with quantum electrodynamics (QED), though the two may act concertedly, as described in the following section.

## 2.4 Space-time Conversion into Matter and Anti-matter

The D-string model presupposes that a D-string in the fully contracted state defines a quantum particle of matter. The quantum particle of matter is posited as the smallest elementary building block of matter, and the precursors to quarks. Quarks were first predicted by Murray Gell-Mann [11], and George Zweig. [12][13]

A quantum particle of matter has the maximal potential energy content for a D-string. However, space-time energy varies: the greater the contracted state, the greater the potential energy content of the space-time D-string. Opposing D-branes on any one of the three axes of a D-string are mirror images of each other, see figure 2. A photon of sufficient energy, interacting

and transferring its kinetic energy into potential energy of a space-time D-string, will contract the D-string into a quantum particle of matter. Subsequently, if enough energy is present, each axis of the quantum particle of matter generates mirror image particle pairs (matter and antimatter) from the abutting space-time D-strings, propagating to form three stereo-chemically distinct matter and antimatter quark pairs.

Paul Dirac developed his relativistic wave equation for the electron in 1928, [14] and this equation predicted that a photon of sufficient energy could produce an electron and a particle that is the same as the electron but with an opposite charge (anti-matter). [15] Carl Anderson is credited for discovering empirical evidence for the existence of anti-matter in a cloud chamber experiment in 1932. [16]

In the D-string model, matter and anti-matter differ in that each is the physical nonsuperposable mirror image enantiomer of the other, which is contrary to Dirac's statement that the particles are identical but differ only in charge sign. If paired enantiomers possess charge, the enantiomers will possess equal and opposite charges due to their mirror image geometry. Restated, what differentiates matter and anti-matter is the geometry of enantiomeric particle pairs, and not the sign of charge of the particle, e.g. a sub-atomic particle without charge such as a neutron has an anti-matter partner.

D-string energy is sub-divided into potential and kinetic types; the kinetic is further sub-divided into geometric and vibrational:

- 1) The potential energy of a D-string is proportional to the level of the contracted state of the D-string; the greater the contracted state, the greater the potential energy. Particle matter consisting of fully contracted D-strings has a higher potential energy state than any potential energy of space-time D-strings.
- 2) Kinetic energy of space-time is of two types:
  - a) Geometric- the process of changing the lengths and sizes of the D-branes and Type I strings of the D-string.
  - b) Vibrational- the rate and magnitude of vibration of D-branes and Type I strings. The vibrational energy of a D-string can be orders of magnitude greater than any geometric or potential energy of a D-string.

The author suggests that the formation of matter and anti-matter occurs when a photon with sufficient kinetic vibrational energy interacts with a single unit of space-time, increasing the potential energy of the space-time D-string by contracting the D-branes and strings. Once the initial unit of space-time has converted into a quantum particle of matter, additional quantum particle pair aggregates are generated from opposing mirror image D-branes of the initial quantum particle of matter. Therefore, three distinct quantum particle matter and anti-matter pairs serve as elemental building blocks for particle matter. Einstein's equation for energy and mass equivalence [17] is shown in equation 2.1,

$$E = mc^2 \tag{2.1}$$

The author posits that energy, matter, and space-time are convertible, with the conversion of space-time into matter occurring when a D-string contracts into its maximal contracted state. Equation 2.2 indicates the mathematical relationships of energy, matter, and space-time. The term  $m$  is the mass of a *single* quantum particle of matter. The state of contraction of a D-string

defines the quantum level of contraction (QL), which indicates the amount of potential energy present. The greater the contracted state, or increase in the magnitude of a QL, the greater the potential energy of the D-string. The potential energy of a space-time unit may be stated mathematically by inserting a term into Einstein's equation, which expresses the QL of the space-time unit;  $QL^x$  is the quantum level of contraction of space-time, and  $QL^n$  represents the QL of a quantum particle of matter. Inputting energy into a D-string increases the D-string's QL. If the D-string absorbs a sufficient amount of energy, then the D-string will contract until the  $QL^x$  equals  $QL^n$  and equation 2.2 reduces to Einstein's equation, at which point space-time converts into matter.

$$E = \left( \frac{QL^x}{QL^n} \right) mc^2 \quad (2.2)$$

Using the modern values for  $G$ ,  $h$ , and  $c$  as listed in CODATA, [18] the values for Planck's natural units of length and time [19] are shown in equations 2.3 and 2.4.

$$l_p = \sqrt{\frac{Gh}{c^3}} = \sqrt{\frac{(6.6742 \times 10^{-8} \text{ cm}^3 \text{ g}^{-1} \text{ s}^{-2})(6.6261 \times 10^{-27} \text{ g} \cdot \text{cm}^2 \cdot \text{s}^{-1})}{(2.9979 \times 10^{10} \text{ cm} \cdot \text{s}^{-1})^3}} = 4.0513 \times 10^{-33} \text{ cm} \quad (2.3)$$

$$t_p = \sqrt{\frac{Gh}{c^5}} = \sqrt{\frac{(6.6742 \times 10^{-8} \text{ cm}^3 \text{ g}^{-1} \text{ s}^{-2})(6.6261 \times 10^{-27} \text{ g} \cdot \text{cm}^2 \cdot \text{s}^{-1})}{(2.9979 \times 10^{10} \text{ cm} \cdot \text{s}^{-1})^5}} = 1.3512 \times 10^{-43} \text{ s} \quad (2.4)$$

In a vacuum not under the influence of matter, a maximally expanded D-string has a length along the x, y, or z-axes equaling one Planck's length. In maximally expanded space-time, one Planck's length is the smallest unit of distance because space-time is quantized and cannot be further sub-divided. Therefore, the smallest possible wavelength of fully expanded space-time also equals Planck's length. Since frequency multiplied by wavelength equals the speed of light,  $c = \nu\lambda$ , then  $\nu = c / \lambda$ , then the highest possible frequency can be expressed as

$$\nu_{\max} = \frac{c}{\lambda} = \frac{2.9979 \times 10^{10} \text{ cm} \cdot \text{s}^{-1}}{4.0513 \times 10^{-33} \text{ cm}} = 7.4000 \times 10^{42} \text{ s}^{-1} \quad (2.5)$$

It has been posited that when a photon of *sufficient* electromagnetic energy interacts with a space-time D-string, the D-string will convert into particle matter. It now must be determined whether or not an individual photon can possess sufficient EM energy for space-time to quantum particle conversion to occur. The author chooses to use the hypothetically highest frequency photon because it contains the greatest energy for possibly transforming space-time into matter. Equation 2.6 shows the relationship of energy as a function of EM frequency. Substituting the value from equation 2.5 into the equation for energy frequency, the calculation of the maximum possible EM energy of a space-time photon is

$$E = hf = (6.6261 \times 10^{-27} \text{ g} \cdot \text{cm}^2 \cdot \text{s}^{-1})(7.4000 \times 10^{42} \text{ s}^{-1}) = 4.9033 \times 10^{16} \text{ g} \cdot \text{cm}^2 \cdot \text{s}^{-2} \quad (2.6)$$

Substituting the energy value of a maximum frequency photon from equation 2.6 into equation 2.1 and solving for mass is shown in equation 2.7,

$$m = \frac{E}{c^2} = \frac{4.9033 \times 10^{16} \text{ g} \cdot \text{cm}^2 \cdot \text{s}^{-2}}{(2.9979 \times 10^{10} \text{ cm} \cdot \text{s}^{-1})^2} = 5.4556 \times 10^{-5} \text{ g} \quad (2.7)$$

It is indeed apparent that one photon can possess enough EM energy to convert space-time into matter. It is also interesting to note the value  $5.4556 \times 10^{-5} \text{ g}$  is equal to Planck's mass, as calculated using currently accepted values for  $G$ ,  $h$ , and  $c$  as listed in CODATA, [20] see equations 2.8 and 2.9,

$$m_p = \sqrt{\frac{hc}{G}} = 5.4556 \times 10^{-5} \text{ g} \quad (2.8)$$

$$m_p = \sqrt{\frac{(6.6261 \times 10^{-27} \text{ g} \cdot \text{cm}^2 \cdot \text{s}^{-1})(2.9979 \times 10^{10} \text{ cm} \cdot \text{s}^{-1})}{6.6742 \times 10^{-8} \text{ g} \cdot \text{cm}^2 \cdot \text{s}^{-2}}} = 5.4556 \times 10^{-5} \text{ g} \quad (2.9)$$

Therefore, Planck's mass is that amount of mass that can be converted from space-time into equal quantities of matter and anti-matter totaling  $5.4556 \times 10^{-5} \text{ g}$  by a maximum frequency photon.

It is proposed in this model that a vacuum is a volume of space devoid of particle matter, and that volume is occupied by space-time D-strings constantly undergoing QL changes as the D-strings equilibrate to approach or attain the same QL with abutting D-strings. The expansion and contraction of the D-strings is analogous to bubbles constituting a quantum foam, [21] and within this foam energetic photons convert D-strings into matter and anti-matter pairs known as *virtual particles*. Energetic photons interacting with space-time to form virtual particles results in a void or *wormhole* in the quantum foam, as the newly formed quantum particles combine and create aggregate masses that tunnel through space-time. The tunneling creates a void where the converted space-time D-strings once resided. Wormholes created by an energetic photon are only quantum sized and have a fleeting existence as adjacent space-time expands to fill the resultant voids. This model defines the universe as being composed of a *finite* number of D-strings, in which *both* the expanded D-strings (quantum space-time), and fully contracted D-strings (particle matter), must be present and generally contiguous. [1] Matter entering a wormhole of sufficient size so that it is no longer in contiguous contact with space-time is defined as being outside of the universe, and would not be under the constraints of known physical laws.

---

<sup>i</sup> D-brane facets of a D-string are often temporarily discontinuous when contracting, but will equilibrate to adjacent D-strings to reestablish physical contact.



## 2.5 Dark Mass and Dark Energy

The question arises as to why the quantized space-time continuum has eluded detection, and the author proposes two reasons: (1) the movement of particle matter through space-time has *no resistance* due to the D-strings actually pushing/pulling any particle matter in uniform motion through space-time, and (2) The local space-time reference frame of a body in uniform motion prevents the quantized space-time of the  $\psi$  from flowing through the body, therefore preventing the detection of the space-time continuum within the reference frame.

Observation of the effects of the space-time continuum does occur, but under the nomenclature of inertia and momentum. A body in uniform motion has a reference frame consisting of local space-time in a uniform state that encapsulates the body, with the non-local space-time of the pilot wave moving around the body, thus moving the body forward. It is the geometry and sequence of equilibration of the space-time pilot wave function ( $\psi$ ) surrounding the body that determines the body's inertia or momentum. A change in energy to the D-strings of the  $\psi$  space-time wave must occur in order to alter the sequence of contraction of the D-strings, which in turn causes a change in velocity of the body. The author hypothesizes that of all of the D-strings that make up the universe, perhaps greater than 90%, are in the expanded space-time state, and are unobservable, i.e. are in a "dark" mass state. However, it is likely there are other types of dark mass contributing to the total amount of dark mass, including but not limited to subatomic particles, [22][23] MACHOs, [24][25] and WIMPs [26][27]. This model's premise of spontaneous expansion by D-strings and subsequent release of energy will be referred to as "dark energy".

The author proposes that the universe came into existence when a D-string expanded from the singularity core of finite mass. D-strings cannot be created or destroyed, therefore there are a finite number of D-strings, and the universe is a bubble composed solely of D-strings. "Outside" of this bubble is undefined, as are any areas within the bubble that are discontinuous with space-time, e.g. the wormhole.

If one mentally runs time backwards to the Big Bang, [28] current mathematics describing the universe will cease to function prior to the Big Bang; this is a result of the absence of the expanded state of the D-strings (space-time), since the D-strings impart the dimensions of both length and time to the universe. If expanded D-strings are not present, then there can be no time, as we understand it; further, without D-strings there can be no measure of length or distance between particle matter. The loss of dimensionality becomes apparent when matter enters a black hole and accretes on the singularity. It is proposed in this model that any singularity consists of a solid core of quantum particles with no space-time intervening between the particles. Matter accreting on a singularity appears mathematically to disappear into a point, and only the gravity of the matter that was seemingly crushed out of existence appears to remain. The author posits that prior to the Big Bang, equations describing the universe cannot function due to the non-existence of expanded D-strings to impart space and time dimensions to the Big Bang singularity. When the first D-string expanded from the Big Bang singularity, then the conditions of the D-string model were met for the universe to come into existence, i.e. both expanded D-strings (space-time) and fully contracted D-strings (matter) must be present and contiguous. The universe would appear mathematically to have exploded out of a point in space.

## 2.6 Time is not Forever – The “No Physical Infinities” Postulate

The last section indicates that energetic photons can convert space-time into matter. It is proffered that space-time also contracts into matter when interacting with the particle matter core of a black hole singularity. Arguing geometrically, the abutting space-time unit D-branes must line up in a fully contracted state with the quantum particle D-branes of the singularity core surface. Once the abutting D-brane fully contracts, the remaining D-branes of the space-time unit equilibrate to a maximally contracted state, resulting in the space-time unit converting into matter. If black holes continuously convert space-time into matter, then eventually all space-time and matter will be drawn onto one supermassive black hole singularity, and the universe would cease to exist. Time has a lifespan, beginning with the big bang and ending at the big crunch. If the universe consists of a finite number of D-strings whose physical properties are finite by the property of quantization, and there is finite time for physical interactions between D-strings, then *there can be no physical infinities*.

### 3. Gravity

This paper’s model defines gravity of a body as a self-interaction of matter creating a field of attraction, and this created field of attraction concertedly interacting with matter.

#### 3.1 Relating D-string Volumetric State to Time, String Tension, and Space-time Energy

The *quantum level of spatial contraction* (QL) is a number that describes the geometric dimensions of the hexahedral quantum space-time unit. Each QL is described by the eight vertices of the hexahedron, and each vertex is described by three spatial coordinates and time, resulting in the 32 parameters that define a QL state. A QL change occurs in a quantum jump (QJ); going from the initiation to completion of a QJ requires a single Planck's time interval. The number of QJ contractions away from a maximally expanded D-string configuration defines the numeric value of the QL of that D-string, see figure 4.

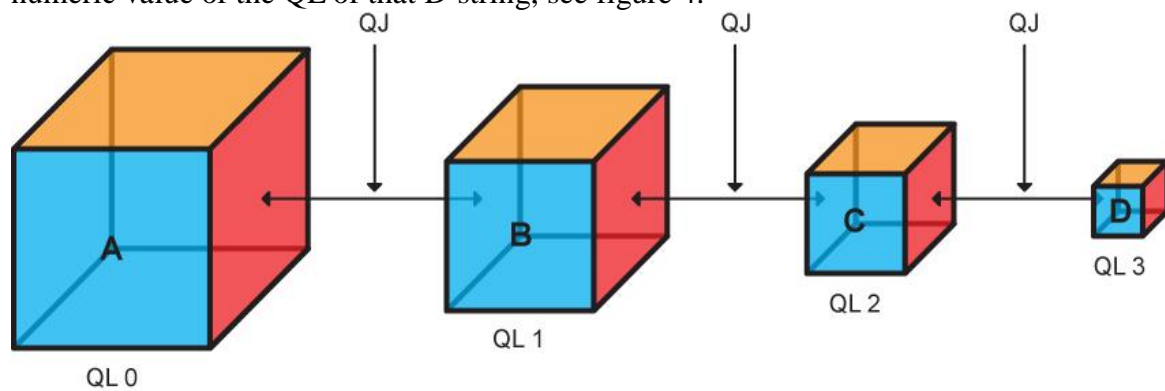

**Figure 4-** Quantum level changes with successive quantum jumps: Cube A represents a D-string in the fully expanded state, and cubes B, C, and D in progressive QJ contracted geometric configurations illustrate the QL of a D-string at each subsequent QJ. The final QL is the net total number of QJs from the maximally expanded state of the D-string. The sizes of the QL contractions in figure 4 are greatly exaggerated for clarity.

The QL of a D-string is a state function, i.e. the change in QL of a D-string depends only on the initial and final QLs of the D-string, and not on the path of the number of expansions and contractions of the D-string leading to the final D-string QL state, see figure 5.

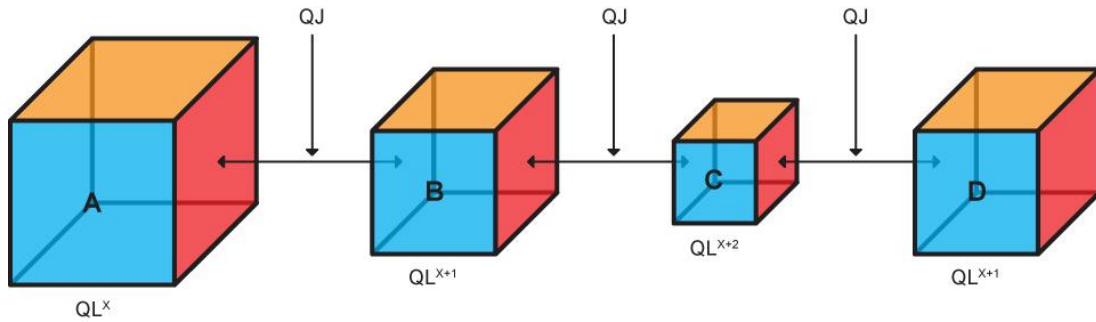
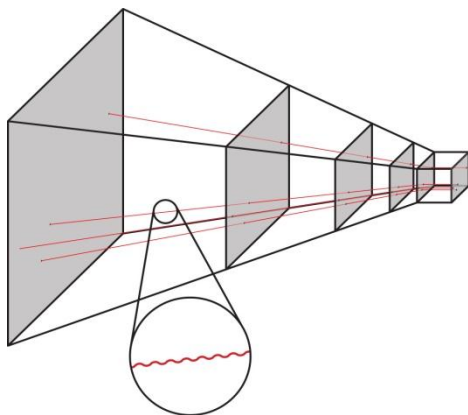

**Figure 5- QL State Function of the D-string.** A D-string undergoes three quantum jumps with an initial arbitrary value of  $x$ , denoted as  $QL^x$ , as in cube A. The D-string quantum jumps and contracts from  $QL^x$  to  $QL^{x+1}$  as in cube B. The D-string now undergoes a quantum jump and contracts a second time to  $QL^{x+2}$  as in cube C. Finally, the D-string Quantum jumps and expands to  $QL^{x+1}$  as in cube D. Though the D-string has undergone three quantum level changes, the net change in the D-string quantum level is one  $QL$ . It is not the *number* of Quantum jumps a D-string undergoes that determines quantum level, but it is the *net difference* in quantum jumps from the initial to the final quantum level.

### 3.2 Interpreting Quantized Space-time String-to-String Tension Differentials as a Field Gradient

Paul Dirac proposed field quantization in 1929, later to be known as relativistic quantum field theory. [29] Paul Dirac stated, "...with the new theory of electrodynamics we are rather forced to have an aether." [30] The author concurs with Dirac's statement and further proposes that the aether is a physical continuum of D-strings.

The author posits that matter warps space-time because quantum particles of matter are smaller than the abutting expanded D-strings of space-time, i.e. D-string geometry distorts due to the process of string alignment and D-brane charge between the quantum particle of matter and the D-strings, see figure 6.



**Figure 6- Space-time warpage by Particle Matter-** The cube represents a quantum particle of matter. The non-cubic hexahedrons represent the D-strings  $s$  of space-time. The strings of the D-strings abutting the quantum particle warp the D-strings when aligning with strings of the particle matter. The strings of the strings warp the strings?

The propagation of string tension from D-strings abutting a particle body to the D-strings not in direct contact with the body results in string tension radiating through the D-strings in proximity to the body. The subsequent outward-radiating string tension from the body defines a quantized *space-time field* (SF). Restated, a space-time field is a result of the tension of the Type I strings at the 2-brane of one D-string interacting and altering the tension of the corresponding strings and D-branes in an abutting D-string. An idealized non-rotating spherical body at rest or in uniform motion has an SF that is symmetrical along all axes of the body. The SF is composed of a gradient of abutting concentric shells of D-strings. All the D-strings of a shell have identical QLs, and the geometry of the D-strings is hexahedral in shape. Expanding outward, each subsequent shell is one QL lower than the previous shell, see figure 7.

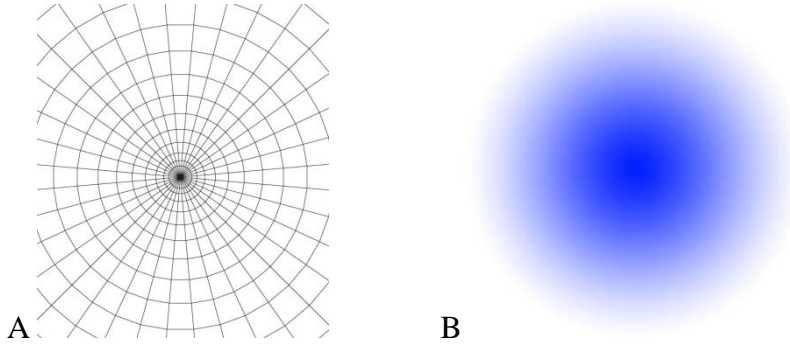

**Figure 4** - (A) The 2-dimensional figure represents a space-time field of concentric QLs of a body (QL size exaggerated for clarity). (B) The 3-dimensional graphic represents a space-time field differential surrounding a body.

This linear reduction is expressed mathematically as, “the quantum level contraction state of space-time exerted by a *single* body is proportional to the mass of the body, and inversely proportional to distance”, as in

$$QL \propto \frac{m}{r} \quad (3.1)$$

where QL is the quantum level of spatial contraction,  $m$  is the mass of the body, and  $r$  is the radius from the center of mass of the body. The QL of a D-string is inversely related to the entropy ( $S$ ) of the D-string,

$$S \propto \frac{1}{QL} \quad (3.2)$$

i.e. the greater the contracted state of a D-string, the higher the QL and the lower the entropy. The QL of a D-string is proportional to the energy level of a D-string,

$$E \propto QL \quad (3.3)$$

i.e. the greater the contracted state of a D-string, the higher the energy content of the D-string. By examination of equations 3.2 and 3.3, it can be seen that energy is inversely proportional to entropy, as shown in equation 3.4.

$$E \propto \frac{1}{S} \quad (3.4)$$

Therefore, in a system where the D-strings expand, entropy increases and energy decreases. The entropy of a D-string is a state function, i.e. the change in entropy of a D-string depends only on the initial and final QL of the D-string, and not on the path of the number of expansions and contractions of the D-string leading to the final D-string QL state. This is a duplication of a previous paragraph.

The QL of a D-string is proportional to the gravitational strength (force) of a D-string. Therefore, an increase in QL of a D-string equals an increase in gravitational force of the D-string. The gravitational force of a *single* body can now be rewritten as Equation 3.5,

$$F_g \propto \frac{m}{r} \quad (3.5)$$

When *two* bodies gravitationally interact, exerting gravitational forces simultaneously on one another, the equation for gravitational force is equal to the product of each body's force on the other, as in

$$F \propto \left( \frac{m_1}{r_1} \right) \left( \frac{m_2}{r_2} \right) \quad (3.6)$$

Since  $r_1$  is the distance from the center of mass of  $m_1$  to the center of mass of  $m_2$ , it equals  $r_2$  which is the distance from the center of mass of  $m_2$  to the center of mass of  $m_1$ , equation 3.6 can now be rewritten as,

$$F \propto \frac{m_1 m_2}{r^2} \quad (3.7)$$

Using the appropriate units of measure, and inserting Newton's gravitational constant into equation 3.7, derives Newton's universal law of gravitation, [<sup>31</sup>] equation 3.8:

$$F = G \frac{m_1 m_2}{r^2} \quad (3.8)$$

The potential energy level of a D-string corresponds to its QL; consequently, an increased QL corresponds to an increase in D-string potential energy, just as a decreased QL represents the reverse. D-strings spontaneously *expand* to a lower QL, but never *contract* spontaneously; this is the equivalent of the second law of thermodynamics translated into this paper's space-time terms, i.e. a region of lower space-time energy cannot spontaneously transfer energy to an abutting region of higher space-time energy. D-strings undergo an increase in QL only by interacting either with D-strings having a higher QL, or with particle matter. Abutting D-strings with unequal QLs will interact in QJs to approach or equal the same QL.

In Quantum Field Theory, a graviton is a hypothetical massless particle that mediates gravity. [<sup>32</sup>] The author proffers that a graviton is not a free moving physical structure traversing an empty void, but instead the graviton is representative of D-string-to- D-string gravitational *string interaction* between abutting D-strings of the space-time continuum. Since the graviton is a propagating string interaction, the graviton is not a discrete particle and has no mass.

### 3.3 Space-time Field of a Uniformly Moving Body

The gravitational movement of any body is due to the concerted interaction of mass and space-time, and is expressed mathematically in Einstein's field equations,

$$R_{\mu\nu} - \frac{1}{2} g_{\mu\nu} R - g_{\mu\nu} \Lambda = -\frac{8\pi G}{c^4} T_{\mu\nu}. \quad (3.9)$$

where  $R_{\mu\nu}$  is the Ricci tensor,  $g_{\mu\nu}$  the metric tensor,  $R$  is the scalar curvature,  $\Lambda$  is the cosmological constant,  $G$  is the gravitational constant,  $c$  is the speed of light, and  $T_{\mu\nu}$  is the stress-energy tensor. The left side of the equation expresses how space-time is warped by matter, and the right side expresses how matter moves through space-time, i.e. the gravity field. Gravity can be thought of as the interaction of a body curving space-time, with the space-time curvature determining how the body moves. The cosmological constant, once thought to be a mistake in Einstein's field equations, may in fact be a necessary mathematical term to express the spontaneous expansion of D-strings as stated in Postulate II of this paper. The energy of spontaneous D-string expansion will be referred to as dark energy.

In the case of a uniformly moving body, the author proffers an interpretation of Einstein's field equations that space-time does not move through a body, i.e. space-time between the particles of matter within the body remain fixed within the body. These fixed space-time D-strings within the body mass are designated the *inertial frame of reference* space-time field. The D-strings surrounding the reference frame sequentially contract, propagating a wave which moves the body forward, and are designated the *space-time field wave* ( $\psi$ ), see figure 11. The steady state of the reference frame of the body stabilizes and maintains the D-string equilibration process of the  $\psi$  differential, maintaining self-propagating movement and preventing the  $\psi$  wave from radiating away. A body moving uniformly through space-time can be visualized as a stable capsule (body and reference frame) surrounded by the  $\psi$  wave which moves the body through space-time, see figure 8. The  $\psi$  wave of this model is not an original concept; it has similarities to the *matter wave* of Louis de Broglie [<sup>33</sup>] and the *pilot wave* of David Bohm. [<sup>34</sup>]

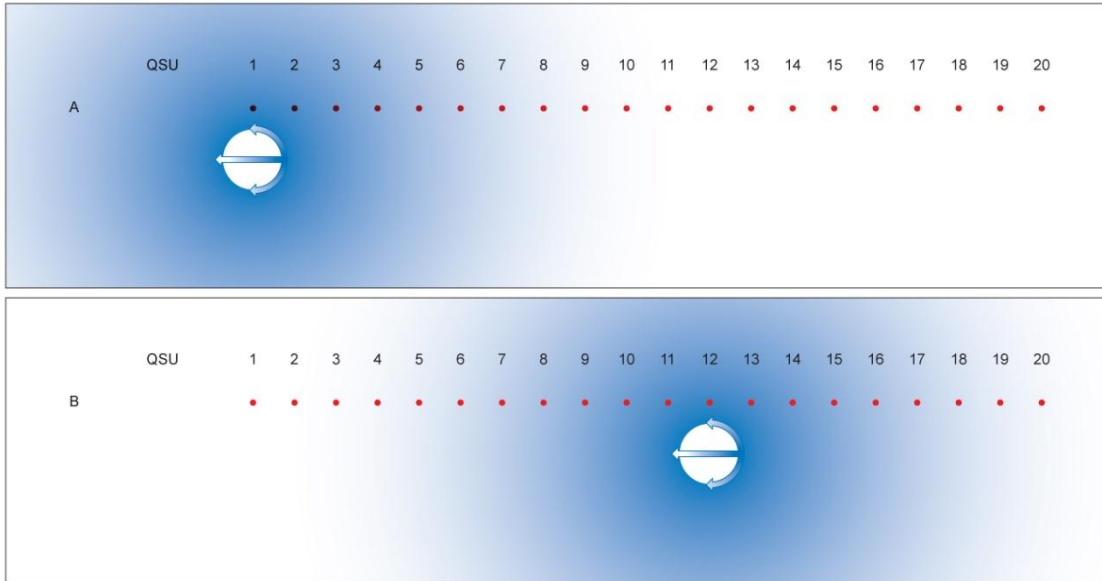

**Figure 5-** Reference frame and  $\psi$  motion diagram. The white dot at the center of the figure represents the reference frame, and the blue surrounding the white dot represents  $\psi$ . The blue arrows indicate the  $\psi$  contracting around the body, moving the body forward.

**3.4 Reference Frame Changes to a Body Under Acceleration**

When the  $\psi$  wave of a body in uniform motion encounters a gravitational field, the D-strings of the  $\psi$  wave interact with the D-strings of the gravitational field disrupting the sequence of contractions of the  $\psi$  wave. The result is a change in the direction and/or speed of the body, i.e. the body undergoes acceleration. The altered  $\psi$  wave interacts with the inertial reference frame, destabilizing the reference frame's constant state, i.e. the body's D-strings of the reference frame will either contract or expand, depending on the density of the gravitational field interacting with the body.

**4. Length Contraction and Time Dilation**

Variations in D-string geometry can be equated to the Lorentz transformations, relating how space and time dilations result from alterations of the physical parameters of the D-string, and that expanded D-strings are in fact physical space-time.

The D-strings surrounding a body undergoing positive linear acceleration initially contract only in the direction of acceleration. When the body ceases to accelerate, reaching a uniform velocity, then all axial lengths of the D-strings equilibrate to approach or equal one another, forming a more contracted, stable, local D-string field around the body. The initial dimensional changes to the D-strings during acceleration are physically felt by a person seated in a vehicle undergoing acceleration as being pulled back into their seat. Once the vehicle attains a steady speed, D-strings equilibrate and the pulling force is no longer felt by the person. Since the D-string axial lengths (space) have contracted, there must be an obligatory change to time

within the field, since space and time are linked, and time slows down in the contracted reference frame of the vehicle.

#### 4.1 Length Contraction

A body that undergoes acceleration produces localized time dilation and length contraction effects. The Lorentz transformations describe these changes, [35] as shown in equation 4.1 for time and 4.2 for length

$$t' = \gamma t, \quad (4.1)$$

$$l' = l / \gamma, \quad (4.2)$$

where  $t'$  is time in a relative moving frame,  $t$  is time in the rest frame,  $l'$  is length in a relative moving frame,  $l$  is length in the rest frame, and  $\gamma = 1 / \sqrt{1 - (v^2 / c^2)}$ .

The forces of electrostatic repulsion must be considered in order to evaluate the physical interpretation of length contraction, the reason for which will be explained in the following paragraphs of this subsection. The ratio of electrostatic force to gravitational force for two electrons is  $4.17 \times 10^{42}$ , [36] as in

$$\frac{F_e}{F_g} = \frac{ke_1^- e_2^- / r^2}{Gm_1 m_2 / r^2} = \frac{ke_1^- e_2^-}{Gm_1 m_2} = 4.17 \times 10^{42}. \quad (4.3)$$

However, the ratio of electrostatic force to gravitational force between identical atoms or identical molecules is variable, depending on the respective number of protons and neutrons constituting the atoms and molecules. Therefore, there is no fixed value for the ratio of  $F_e$  to  $F_g$  but  $10^{42}$  suffices as an approximation. The following paragraphs will utilize this large ratio in explaining the resistance of a body in motion to contract.

As stated in section 3.1, as a moving body's local space-time contracts, the body's gravity increases. However, at speeds less than  $0.99c$  the increase in gravity is relatively weak, and is insufficient to overcome the  $10^{42}$  greater repulsive electromagnetic force, which would be required to contract the body in proportion to the Lorentz length contraction equation.

To date, no published experiment has confirmed the existence of length contraction of a moving body by *direct* observation. Well-known experiments that fail to show length contraction include Trouton-Rankine [37] and Tomaschek. [38][39][40] Several experiments purport to confirm the existence of length contraction by *indirect* evidence, in particular Pound-Rebka [41][42] and Pound-Snider. [43] The author concurs that length contraction does occur when a body is in motion, but he proffers the current interpretation that the body contracts is incorrect, and posits it is *space-time* surrounding a moving body that contracts, and not the body itself. The following section will elucidate D-string model length contraction and time dilation of a moving body.



## 4.2 Time Dilation

Length contraction of the local space-time surrounding the body leads directly to time dilation of the body as the following example illustrates. If a body is accelerated to a uniform velocity of .866 the speed of light, the local reference frame of the body interacts with the denser  $\psi$  wave, contracting the D-strings of the reference frame of the body. Substituting .866 into Equation 4.2 yields a length contracture of 0.5. The D-strings initially contract only in the direction of motion, but the strings within the D-string undergo equilibration to approach or attain equal lengths in all axes, as assumed from “D-string Model premise 7”. Therefore, D-strings of the reference frame contract along *all three axes* to one-half their initial length, which doubles the number of D-strings between any two particles of matter.

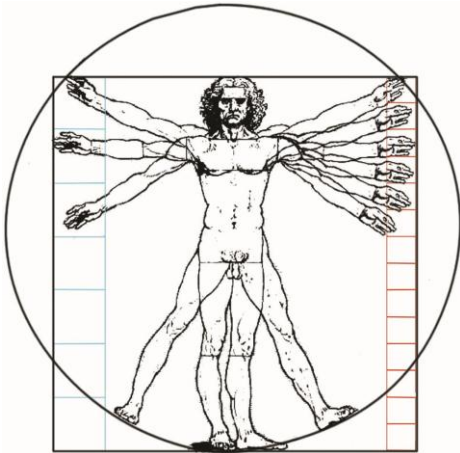

Figure 6

In Figure 6, the figure’s right arm side represents a space-time field density of seven D-strings from head to toe, and the figure’s left arm side represents a space-time field density of fourteen D-strings from head to toe. It is possible to observe time dilation between these two fields when the model raises both arms simultaneously from his navel to the top of his head. The figure’s right arm traverses three D-strings at a rate of one D-string per unit time  $T_0$ , and the model’s left arm traverses six D-strings at the same rate of one D-string per unit time  $T_0$ . It is apparent to a non-local observer, i.e. an observer outside of the model’s local reference frame, that the model’s left arm takes twice as long to traverse from his navel to the top of his head due to its passing through twice as many space-time D-strings as the right arm.

Placing a clock in the right hand and an identical clock in the left hand, both clocks will register three time units for their respective arms to move from the navel to the top of the head. This is not a paradox because even though the figure’s left side takes twice as long to travel the distance, the clock would run half as fast in the left side’s denser space-time field. This is because the figure’s left side clock’s moving parts would also have to pass through twice as many D-string’s in the figure’s left hand space-time field and would run at half speed. Therefore, a local observer in either the left hand or right hand space-time field will observe the clock register the passage of three units of time to move the arm from the navel to the head, but an outside observer not within either reference frame will observe the clocks running at different speeds. Physical time dilation is therefore the change in time required to move between points of matter under varying space-time density conditions.

The linking of space and time as ‘space-time’ implies that any change in space inextricably requires a corresponding change in time. If a body that has undergone acceleration produces *time* dilation, then a length change will have occurred to the *space* surrounding the body, i.e. length contraction occurs to the body’s local space-time and not to the body itself.

### 4.3 Relativistic Mass Increase

How does an object increase in relativistic mass? Does the object actually gain more atoms or molecules? Could the protons, neutrons, and electrons of the object somehow increase in mass? It seems unlikely to the author that any of these things occur; instead the relativistic mass increase is not an actual increase in mass, but is simply interpreted mathematically as an increase in mass because of the increase in space-time density. due to the contracture of local space-time of the moving object. it is space-time that changes and not the mass of the accelerated body.

## 5. Speed of light

Albert Einstein stated in his second postulate of special relativity, “Light is always propagated in empty space with a definite velocity  $c$  which is independent of the state of motion of the emitting body.” [44] This section will attempt to elucidate the underlying physical nature of Einstein’s axiomatic statement.

### 5.1 Planck’s Units of Length and Time

Equations and original values for Planck’s natural units of length and time are shown in equations 5.1 and 5.2 [45]. Note however that Planck’s values for  $G$ ,  $h$ , and  $c$  are inaccurate compared to modern accepted measurements as listed in CODATA. [46] Consequently, substitution of currently accepted values of these constants into the formulae yields a correspondingly modern value for Planck’s length and time as shown in equations 5.3 and 5.4.

$$l_p = \sqrt{Gh/c^3} = 4.13 \times 10^{-33} \text{ cm} \quad (5.1)$$

$$t_p = \sqrt{Gh/c^5} = 1.38 \times 10^{-43} \text{ s} \quad (5.2)$$

$$l_p = \sqrt{\frac{Gh}{c^3}} = \sqrt{\frac{(6.6742 \times 10^{-8} \text{ g} \cdot \text{cm}^2 \cdot \text{s}^{-1})(6.6261 \times 10^{-27} \text{ g} \cdot \text{cm}^2 \cdot \text{s}^{-1})}{(2.9979 \times 10^{10} \text{ cm} \cdot \text{s}^{-1})^3}} = 4.0513 \times 10^{-33} \text{ cm} \quad (5.3)$$

$$t_p = \sqrt{\frac{Gh}{c^5}} = \sqrt{\frac{(6.6742 \times 10^{-8} \text{ g} \cdot \text{cm}^2 \cdot \text{s}^{-1})(6.6261 \times 10^{-27} \text{ g} \cdot \text{cm}^2 \cdot \text{s}^{-1})}{(2.9979 \times 10^{10} \text{ cm} \cdot \text{s}^{-1})^5}} = 1.3512 \times 10^{-43} \text{ s} \quad (5.4)$$

## 5.2 The Photon

The author proffers that a photon is not an individual particle traversing an empty void, but instead the photon is a D-string *vibrational interaction* between abutting D-strings of the space-time continuum. If the photon is a propagating D-string *interaction*, *i.e. a process*, and not a discrete particle, then the photon has no mass. However, since the photon is isolated to one D-string at a time as it propagates, it appears as a particle, and as the photon propagates, an accompanying EM SF occurs at each D-string as the EM pulse traverses through abutting D-strings, and the SF appears as a wave as it passes an observer.

More than one photon can have its EM string interactions pass simultaneously through an individual D-string, along a different EM string not occupied by another photon. Therefore, the photon, as well as other zero mass bosons, can occupy the same space (D-string) at the same time. On the other hand, fermions are not like the bosons, but are fully contracted D-strings that are solid particles of matter, and cannot occupy the same space at the same time; there is simply no space for the fermions to pass through one another because the D-strings are fully contracted.

## 5.3 The Speed of Light

The quantum jump contraction of the D-string occurs in the same invariant time interval (Planck's time), regardless of the contracted state of the D-string. Equation 5.5 shows the computation of the speed of light of a photon traversing maximally expanded space-time ( $c_m$ ), as

$$c_m = \frac{l_p}{t_p} = \frac{4.05 \times 10^{-33} \text{ cm}}{1.3512 \times 10^{-43} \text{ s}} = 2.9979 \times 10^{10} \text{ cm} \cdot \text{s}^{-1} \quad (5.5)$$

By inspection of the algebraic formulae, this outcome is obvious, for it is self-defining,

$$c = \frac{l_p}{t_p} = \frac{\sqrt{Gh/c^3}}{\sqrt{Gh/c^5}} = \sqrt{\frac{Gh \cdot c^5}{Gh \cdot c^3}} = \sqrt{c^2} = c \quad (5.6)$$

However, using this model's concepts of length contraction and time dilation, we can now state the speed of a photon traversing a local reference frame of contracted space-time ( $c_c$ ) to be

$$c_c = \frac{l_c}{t_p} \quad (5.7)$$

where  $l_c$  represents the contracted length of the D-string, and  $l_c < 4.0513 \times 10^{-33} \text{ cm}$ . Equation 5.7 shows that the speed of light is not constant in absolute distance crossed per unit time, but is *invariant* in traversing one D-string per Planck's time unit, see figure 10.

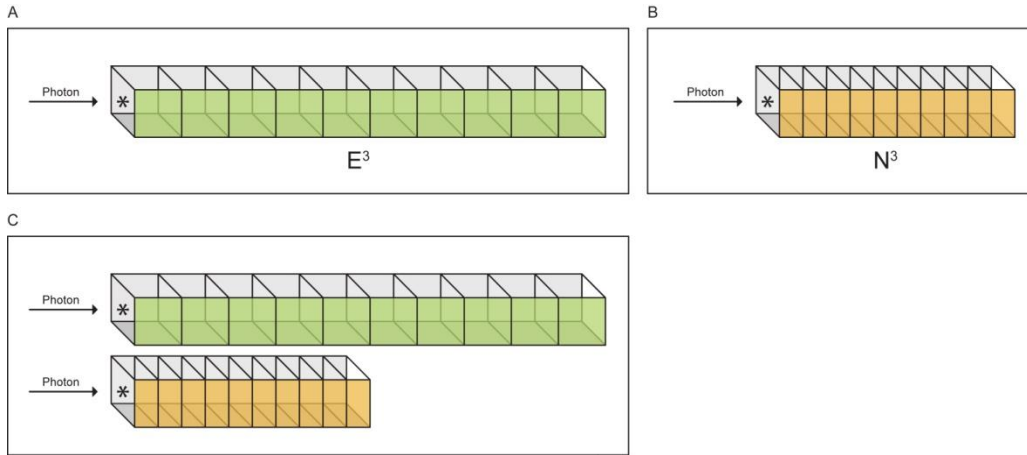

**Figure 7- Euclidean ( $E^3$ ) and Non-Euclidean ( $N^3$ ) Geometries;** (A) Euclidean reference frame with fully expanded D-strings having equal lengths along x, y, and z-axes with the time required to traverse 10 fully expanded D-strings equaling  $10 \times T_p = 10 T_p$ , and the distance traversed equaling  $10 \times L_p = 10 L_p$ . (B) Non-Euclidean reference frame with warped or contracted space-time with D-string axes not equal in length. The D-strings in this case are contracted  $\frac{1}{2}$  in direction of motion. The time to traverse ten contracted D-strings equals,  $10 \times T_p = 10 T_p$  and the distance traversed equals,  $10 \times \frac{1}{2} L_p = 5 L_p$ . (C)  $E^3$  juxtaposed to  $N^3$ - the photon will appear to move at half the speed and move half the distance in  $N^3$  as compared to  $E^3$ .

The speed of light within a local reference frame of a moving body always appears to be  $2.9979 \times 10^{10} \text{ cm} \cdot \text{s}^{-1}$ , because an observer within a stable reference frame is surrounded by D-strings with the same contraction state or QL, resulting in the observer undergoing time dilation exactly equal to the time increase a photon requires to traverse the increased number of D-strings.

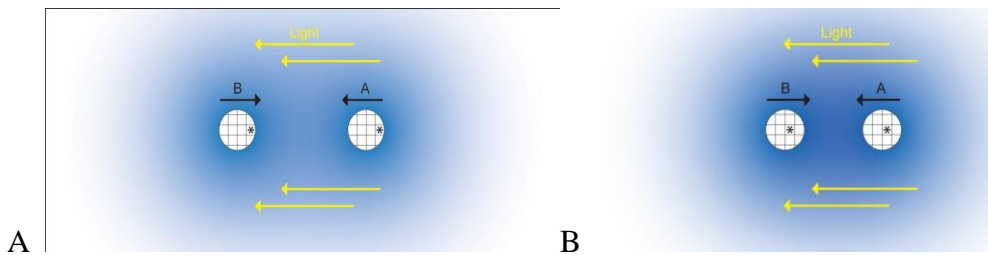

**Figure 8-** (A) shows two bodies **A** and **B** moving in opposite directions and at the same speed, as indicated by the black bars above the bodies. Photons from a light source coming from the same direction as body **A** enter the reference frame of body **A** and body **B** at the same instant, as indicated by the asterisk. Figure (B) shows that since both bodies are moving at the same speed, the bodies have identical space-time densities of their respective reference frames, and the photons of both bodies propagate at the same rate of one D-string per Planck's time. An observer within the reference frame of either body **A** or **B** will observe the speed of light at the same speed, despite moving in opposite directions from the light source.

The author suggests the *null result* of Michelson-Morley's experiment [47] was a consequence of the false assumption that the ether (space-time continuum) moves through the interferometer because the earth is moving through the ether. The author proposes that the arms of the interferometer used in Michelson-Morley's experiment were within a rapid equilibrating

stable reference frame, resulting in uniform measurement of the speed of light, producing the null result for detecting the ether.

## Concluding Remarks

The D-string hidden variables model presented in this paper endeavors to elucidate a relationship for a physical structure of space-time as another state of matter. This paper does not question the validity or accuracy of current mathematics describing quantum mechanics and relativity as put forth by Planck, Einstein, Dirac, et al. However, the mathematics do not describe the underlying nature of the universe. This model suggests a physical interpretation of the mathematics that describes space-time and matter. The basis of this D-string model, i.e. that space is not empty, and is quantized, allows for the extrapolation to new interpretations for gravity, time dilation, and the speed of light; these physical interpretations offer a view of the universe based upon a possible physical reality via the D-string.

The author proposes it is no coincidence that Planck's natural units describe the properties of the D-string, and puts forth that the values of  $G$ ,  $h$ , and  $c$  are determined by the properties of the D-string. The calculation by Planck to determine his natural units by using  $G$ ,  $h$ , and  $c$  was the mathematical process of inadvertent reverse engineering, which necessarily revealed the properties of the D-string.

**Acknowledgements-** the author would like to thank the following people for their help in reviewing this paper and their thoughtful suggestions: Evan Oulashin, Scott Heen, Greg Dawson, Mark John Holady, Daniel Wilkens, Michael Dawson, Kathy Dawson, and William Renfroe.

---

[<sup>1</sup>] M. Planck, "Uber Irreversible Strahlungsvorgange," *Preussischen Akademie der Wissenschaften* 5 440-480 (1899).

[<sup>2</sup>] Ibid.

[<sup>3</sup>] P. Horava, "Background Duality of Open String Models," *Physics Letters* **B231** 351 (1989).

[<sup>4</sup>] J. Dai, R. Leigh, and J. Polchinski, "New Connections Between String Theories," *Modern Physics Letters* **A4** 2073 (1989).

[<sup>5</sup>] J. Polchinski, "Dirichlet Branes and Ramon-Ramon Charges," *Physical Review Letters* **75** 4724 (1995).

[<sup>6</sup>] A. Cheng, and D. Cheng, "Heritage and Early History of the Boundary Element Method Dirichlet Boundary Conditions," *Engineering Analysis with Boundary Elements* **29** 268-302. (2005).

- 
- [<sup>7</sup>] E. Witten, "D-branes and K Theory," *Journal of High Energy Physics* 9812:019 (1998).
- [<sup>8</sup>] H. Minkowski, Address delivered at the 80th Assembly of German Natural Scientists and Physicians, (Cologne, 1908). Published in *Physikalische Zeitschrift* **10**, 104-111 (1909).
- [<sup>9</sup>] E. Witten, lecture delivered at *Strings '95*, a conference held at USC in March, (1995).
- [<sup>10</sup>] P. Horava and E. Witten, "Heterotic and Type I String Dynamics from Eleven Dimensions," *Nuclear Physics* **B460**, 506 (1996).
- [<sup>11</sup>] M. Gell-Mann, "A Schematic Model of Baryons and Mesons," *Physics Letters* **8**, 214-215 (1964).
- [<sup>12</sup>] G. Zweig, "An SU(3) Model for Strong Interaction Symmetry and its Breaking," *CERN Report* **8182-TH**, 401 (1964).
- [<sup>13</sup>] G. Zweig, "An SU(3) Model for Strong Interaction Symmetry and its Breaking: II," *CERN Report* **8419-TH**, 412 (1964).
- [<sup>14</sup>] P. Dirac, "The Quantum Theory of the Electron," *Proceedings of the Royal Society of London Series A*, Containing Papers of a Mathematical and Physical Character **117**, (778) 610-624 (1928).
- [<sup>15</sup>]Ibid.
- [<sup>16</sup>] C. Anderson, "The Positive Electron," *Physical Review* **43**, 491 (1933).
- [<sup>17</sup>] A. Einstein, "Does the Inertia of a Body depend on its Energy Content?" *Annalen der Physik* **18** 639-641 (1905).
- [<sup>18</sup>] CODATA Committee on data for Science and Technology, page 63, Table XXVI (2005).
- [<sup>19</sup>] H. Lorentz, "Electrodynamic Phenomena in a System Moving with any Velocity Less than that of Light," *Proceedings of the Academy of Science of Amsterdam* **IV**, 669-678 (1904).
- [<sup>20</sup>] CODATA Committee on data for Science and Technology, page 63, Table XXVI (2005).
- [<sup>21</sup>] J. Wheeler, "Geons," *Physical Review* **97** 511-536 (1955).
- [<sup>22</sup>] J. Bahcall, "Neutrino Astrophysics," Cambridge University Press. ISBN 0-521-35113-8 (1989).
- [<sup>23</sup>] D. Griffiths, "Introduction to Elementary Particles," Wiley, John & Sons, Inc. ISBN 0-471-60386-4, (1987).

---

[<sup>24</sup>] C. Alcock et al., "The MACHO Project: Microlensing Results from 5.7 Years of LMC Observations," *Astrophysics Journal* **542**, 281-307 (2000).

[<sup>25</sup>] P. Tisserand, et al., "Limits on the Macho Content of the Galactic Halo from the EROS-2 Survey of the Magellanic Clouds," Submitted to *Astronomy and Astrophysics*.

[<sup>26</sup>] F. Ferrer, L. Krauss, and S. Profumo, "Indirect Detection of Light Neutralino Dark Matter in the NMSSM," *Physical Review* **D74**, 115007 (2006).

[<sup>27</sup>] J. Carr, G. Lamanna, and J. Lavalle, "Indirect Detection of Dark Matter," *Reports on Progress in Physics* **69**, 2475-2512 (2006).

[<sup>28</sup>] G. Lemaître, "The Beginning of the World from the Point of View of Quantum Theory," *Nature* **127**, 706 (1931).

[<sup>29</sup>] P. Dirac, "Quantum Mechanics of Many-Electron Systems," *Proceedings of the Royal Society of London Series A* **123**, 714-733 (1929).

[<sup>30</sup>] P. Dirac, "Is There an Aether," *Nature* **168**, 906 (1951).

[<sup>31</sup>] I. Newton, "Philosophiae Naturalis Principia Mathematica," (1687).

[<sup>32</sup>] D. Blokhintsev and F. Gal'perin, *Pod Znamenem Marxisma* **6**, 147 (1934).

[<sup>33</sup>] L. de Broglie, "Researches on the Quantum Theory," Thesis (1924); L. de Broglie, *Annalen der Physik* **3**, 22 (1925).

[<sup>34</sup>] D. Bohm, "A Suggested Interpretation of the Quantum Theory in Terms of Hidden Variables," *Physical Review* **85**, 166–179 (1952).

[<sup>35</sup>] H. Lorentz, "Electrodynamic Phenomena in a System Moving with any Velocity Less than that of Light," *Proceedings of the Academy of Science of Amsterdam* **IV**, 669-678 (1904).

[<sup>36</sup>] R. Feynman, "The Feynman Lectures on Physics," Commemorative Edition, page 7-10, (1989).

[<sup>37</sup>] F. Trouton and A. Rankine, "On the Electrical Resistance of Moving Matter," *Proceedings of the Royal Society of London* **80**, 420 (1908).

[<sup>38</sup>] R. Tomaschek, "The Conduct of Light of Extraterrestrial Light Sources," *Annalen der Physik* **73**, 105–126 (1924).

[<sup>39</sup>] R. Tomaschek, "Concerning an Experiment on the Location of Electrodynamic Effects of the Movement of the Earth at High Altitudes II," *Annalen der Physik* **80**, 509–514 (1926).

---

[<sup>40</sup>] R. Tomaschek, "Comments on My Tests on the Detection of Electrodynamical Effects at High Altitudes," *Annalen der Physik* **84**, 161–162 (1927).

[<sup>41</sup>] R. Pound and G. Rebka Jr. "Gravitational Red-Shift in Nuclear Resonance," *Physical Review Letters* **3**, 439-441 (1959).

[<sup>42</sup>] R. Pound and G. Rebka Jr. "Apparent Weight of Photons," *Physical Review Letters* **4**, 337-341 (1960).

[<sup>43</sup>] R. Pound and J. Snider, "Effect of Gravity on Nuclear Resonance," *Physical Review Letters* **13**, 539-540 (1964).

[<sup>44</sup>] A. Einstein, "Zur Elektrodynamik bewegter Körper," *Annalen der Physik*, **17** (1905).

[<sup>45</sup>] H. Lorentz, "Electrodynamical Phenomena in a System Moving with any Velocity Less than that of Light," *Proceedings of the Academy of Science of Amsterdam* **IV**, 669-678 (1904).

[<sup>46</sup>] CODATA Committee on data for Science and Technology, page 63, Table XXVI (2005).

[<sup>47</sup>] A. Michelson and E. Morley, "The Relative Motion of the Earth and the Luminiferous Ether," *American Journal of Science* **22**, 120-129 (1887).