



# Acoustic Levitation Using Arduino

Sri Vrushank Ayyagari

Bachelor of Science in Physics, Mathematics & Electronics,

CHRIST(Deemed To Be Univeristy),

Bengaluru,India.

email:srivrushank@gmail.com

**Abstract:** Using acoustic radiation pressure, an attempt to levitate low density objects using ultrasonic transducers, and other components driven by Arduino board, H-Bridge, etc. The levitation is achieved by ultrasonic transducers producing vibrations between molecules(sound-waves) with certain frequency that could levitate the object with comparable sizes(w.r.t wavelength corresponding to the acoustic waves being produce). The idea is to form standing waves which will counteract the gravitational force of the earth acting downwards, where these waves create nodes and anti-nodes opposite to the gravitational force, enabling the object to levitate mid-air.

**Keywords:** Acoustic (sound) Waves, Ultrasonic Transducers, Standing Waves, Arduino, Levitation.

## 1. Introduction

Levitation is the process by which an object is suspended against gravity by the application of a force equal to the object's weight. Levitation can be achieved by various forces, viz; Acoustic, Electrical, Optical and Magnetic forces.

In this project (**Acoustic levitation**) is considered to levitate low-mass/density objects. It employs sound waves(acoustic radiation pressures) which can travel only through a medium and are caused due to the perturbations on the molecules by the propagation of sound waves.

While propagation, they transfer momentum across the molecules by collisions in the medium leading to formation of pressure differences, which is the reason for the force produced by sound waves.They are weak forces i.e they are unable to move or perturb an object in the medium but they are strong enough to counteract the gravitational forces of our planet.

Waves with high intensities and frequency are the basic requirements . It solely depends on the wavelength of the sound waves which can levitate objects with comparable dimension or in simple words, comparable size. The equation which describes such mechanical sound waves in a medium (presence of matter) in generalized form is given by equation(1), which shows that speed of the sound-waves ( $c_s$ ) depends on the rate of change of pressure with respect to the density of the medium.

$$\frac{\partial^2 \Psi(x, t)}{\partial x^2} = \frac{1}{c_s^2} \frac{\partial^2 \Psi(x, t)}{\partial t^2} \quad (1)$$

## 2. Project Description

A power supply source for powering up the **H-Bridge**, which divides the voltage directed to two out-

puts for each transducer. This voltage serves as the minimum power required for the functioning of ultrasonic transducers in certain frequency range directed by the **micro-controller**, which can be altered by the program code.

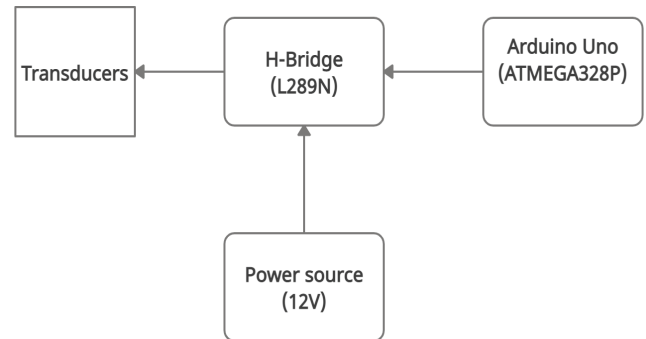

**Figure 1:** Block diagram of the project.

**Arduino** which contains the source code for generating the required frequency which shall be pumped through the analog ports into the H-Bridge input pins, which shall feed the frequency into **ultrasonic transducers**.

## 3. Circuit Details

The model or outline circuit is made using an online website **Tinkercad**<sup>[3]</sup>. The basic or simple levitation can be achieved using the components as shown in figure 2. The simplicity of the circuit makes the project doable for anyone interested in testing the theory within any household.

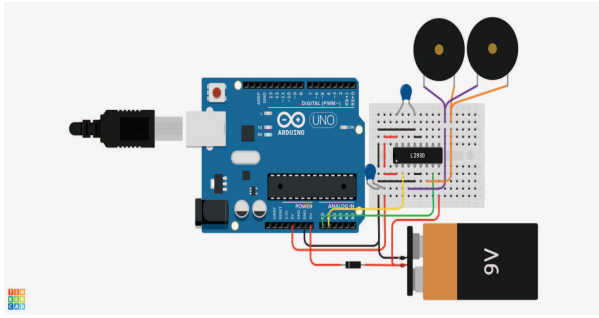

Figure 2: Circuit diagram(model)

Table 1: Ports and Pins for the ATMEGA328P chip for Port Manipulation.

| Ports | Pins             |
|-------|------------------|
| D     | digital(0 to 7)  |
| B     | digital(7 to 13) |
| C     | analog(0 to 7)   |

### 3.1. Arduino Uno

This is the micro-controller chip being used for generating the frequency required to produce ultrasonic sound waves through the transducers.

The port-pins of the arduino are selectively programmed to perform certain tasks such as sending bit by bit signals through the wires connected to the H-Bridge(L289N).

The i/o ports are manipulated in the code so that the direct link could establish a higher efficiency and bit-rates for the micro-controller to send the signals. Each micro-controller on arduino board has difference sets of port registers which can be manipulated by defining them in the code. This also allows minimal amount of memory usage by the chip to operate.

### 3.2. H-Bridge(L289N)

It is used for controlling and transmitting signals into the transducers which also amplifies the frequency to required range and sets the constant feedback loop to produce sound waves.

The input pins are connected to the analog output ports of arduino, which sets up the signal frequency into the driver, which is amplified by the power supply of +12V from DC source(adapter), and external +5V from arduino port. The output pins to pump the derived signals of certain frequencies into the transducers(here OUT-12).

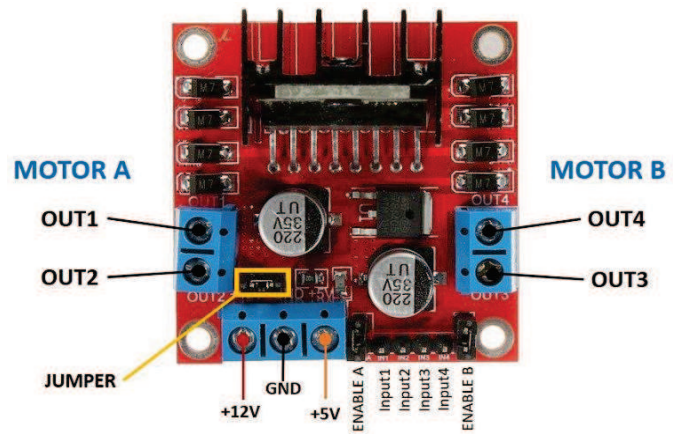

Figure 3: H-Bridge(L289N). Source[6]

### 3.3. Ultrasonic Transducers

The AC signal frequency that is being fed into the transducers from the H-bridge are converted into ultrasonic sound-waves that make the vibrations that propagate in the medium(air), with an operating voltage of 5V.



Figure 4: Ultrasonic Transducers.

Transmission of voltage(around 6V) power into each transducers for them to be producing frequency with amplitudes greater than that of the original AC frequencies sent by the arduino analog pins. Whenever these waves confront an obstacle, they reflect and bounce back to the receiver, which can then be used to calculate the distances.

This is the basic idea behind these sensor modules using transducers. The polarity of these transducers are random and in this project there is no need to check for polarity of these transducers, since the output from the H-Bridge is a uni-polar signal voltage.

## 4. Theory & Working

There are different types of Levitation possible using acoustics. In this project, I have used **Standing Wave Levitation**.

Bi-directional arrangement of transducers is made,

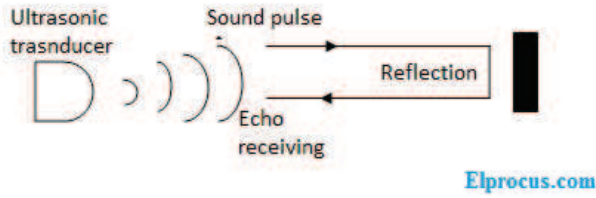

**Figure 5:** Representation of waves propagating from the ultrasonic transducer and a reflector.

such that they face their vibrating crystals which produce the sound-waves with certain frequencies.

Now, due to this sort of arrangement, the pressure-waves which propagate along a particular direction(say  $x$ ) with a phase(say  $\phi$ ). There will be another wave propagating in opposite direction to the previous one, facing downwards(say  $-x$ ).

As is observed, there is a tiny object levitating at the mid-point of the both transducers path. The point at which the object is able to levitate is called a **Node** of the standing wave, which is formed by the super-positioning of the sound pressure waves directed along each other with same(approximately) frequencies.

This makes the phase difference between the transmitted and reflected waves to be ( $\Delta\phi = 180^\circ$ ) with respect to each other. This omits out the horizontal component of the waves and the vertical pressure waves component is the reason for the levitation of the object as shown in the diagram.

Consider a wave which is described by the equation :

$$\Psi(x, t) = Ae^{i(kx \pm \omega t)} \quad (2)$$

This is a general wave-equation for matter-waves that propagate along the one-dimensional ( $x$ -direction), considering it as **one-dimensional**, because the ultrasonic waves traverse and exchange momentum(energy) along single-direction. And considering it in our 3D view, it can be visualized as a plane-wave propagating through space-time. But, since there are no complex components of the wave function in this case, it may be approximated it as a sine-wave:

$$\Psi(x, t) = A \sin(kx \pm \omega t) \quad (3)$$

where  $k = \frac{2\pi}{\lambda}$  is the propagation constant,  $\omega = 2\pi f$ , 't' is the time period of the wave to traverse across in cycle and 'x' is the displacement traversed by the wave in that direction. Sound waves can also be considered as pressure waves, i.e. variations of pressure at various

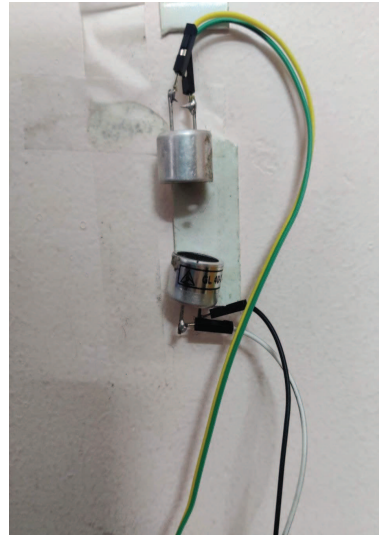

**Figure 6:** Levitating polystyrene(thermocool-ball) with basic setup producing standing-waves.

points. For a sinusoidal wave, the pressure fluctuates same as sinusoidal waves. Now, let  $p(x, t)$  be the pressure fluctuation at a particular instant, then let :

$$\psi_1(x, t) = A \sin(kx - \omega t) \quad (4)$$

be the wave equation for a wave travelling from left to right (or say upwards in our case) and let:

$$\psi_2(x, t) = A \sin(kx + \omega t) \quad (5)$$

be the wave equation for the wave traveling in opposite direction to the other(say in our case downwards). Then let us consider that the propagation of these two waves are through a hollow cylinder, let the volume of this chamber(cylinder) be  $V$  and pressure be  $P$ .

Between the initial state of the wave and final there is a displacement of molecules( $\Delta x$ ) through the  $x$ -direction given by wave-equations,  $y_1 = \psi(x, t)$  and  $y_2 = \psi(x + \Delta x, t)$  respectively, then according to acoustic pressure laws:

1. if  $y_2 > y_1$ ,  $V$  increases and  $P$  decreases
2. if  $y_2 < y_1$ , then  $V$  decreases and  $P$  increases
3. if both are same in magnitude, there are no changes made.

then the change in volume due to the compression and decompression is given by:

$$\Delta V = S(y_2 - y_1) = S[\psi(x + \Delta x, t) - \psi(x, t)] \quad (6)$$

where  $S$  is the surface area, from here, calculation of the fractional change in volume with respect to change

in pressure fluctuations, given by:

$$\frac{dV}{V} = \lim_{\Delta x \rightarrow 0} \frac{[S[\psi(x + \Delta x, t) - \psi(x, t)]]}{S\Delta x} = \frac{\partial y(x, t)}{\partial x} \quad (7)$$

and calculate the pressure fluctuations using the **Bulk modulus** of the medium given by:

$$P(x, t) = -B \frac{\partial y(x, t)}{\partial x} \quad (8)$$

where **B** is the Bulk modulus constant, and the negative sign here signifies that the decrease in pressure with respect to gradient of wave-compression or decompression(volume change) the **-B** compensates the change and maintains equilibrium state. From previous equations of pressure fluctuations, can be rewritten as:

$$P(x, t) = -B(kx) \sin(kx \pm \omega t) \quad (9)$$

here the value  $-Bkx$  signifies the maximum pressure amplitude that can be achieved(taking the sine value as 1).

These pressure fluctuations are the reasons causing the force(upwards) against gravity(acting downwards), and also due to the formation of nodes and anti-nodes through standing-waves, the pressure gradient creates **sound pressure vortices**, where at each vortex it is found to compensate the forces acting at a **-singular point**, the angular momentum plays a role.

This is the reason why rotation of the objects which are placed at the nodal points of the standing waves is observed.

Objects have a motion(very small oscillations) which are floating due to the forces acting on them, these can be assumed to be harmonic oscillations, since they are oscillating about the nodes or equilibrium points. So, the following can be assumed:

$$\sin \theta \sim \theta \quad (10)$$

then,

$$\cos \theta = 1 - \frac{\theta^2}{2} \quad (11)$$

and the equation describing the harmonic oscillatory motion of these objects at nodal points is given by:

$$\frac{\partial^2 \theta}{\partial t^2} + \omega^2 \theta = 0 \quad (12)$$

which has a solution as:

$$\theta = \theta_0 e^{-i\omega t} \quad (13)$$

where  $\theta_0$  is the initial phase of the wave.

#### 4.1. Stable and Unstable nodes

Considering it is a conservative system in which the potential energy is a function of only position(x) and the transformation of equations describes in generalised co-ordinates does not perturb the system with respect to time explicitly then, the system is said to be in equilibrium if the net forces acting on the system are 0 in magnitude:

$$F_{net} = -\left(\frac{\partial V(x)}{\partial x}\right) = 0 \quad (14)$$

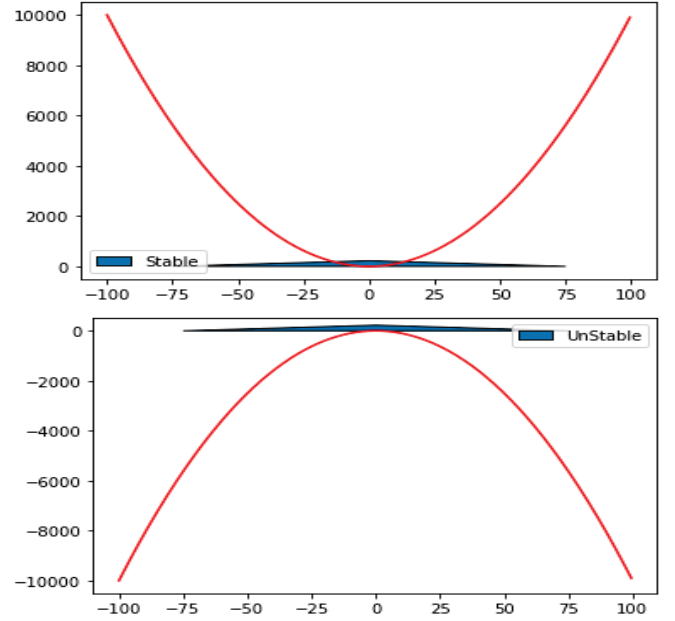

**Figure 7:** Representation of stability for potential(curve) produced due to harmonic oscillations.

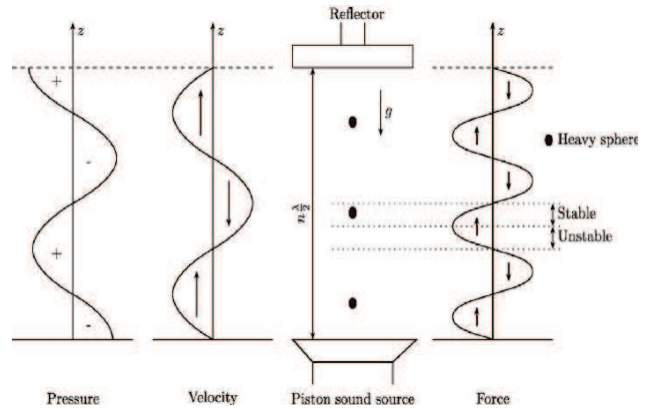

**Figure 8:** Basic representation of the working.

**Note:** Ignore the x and y values for the graph, these are used for general plotting purposes as an example.

It is said to be in equilibrium, if the particle's displacement is **bounded** under perturbations is very

minimal(i.e. **P.E is min**), for example at rest position of the particle at a point. Which is opposite in the case for instability.

Figure 7 is assumed to be the potential energy curve, where the **minima** of the graph represents the stable point, whereas the **maxima** of the below graph gives unstable equilibrium singular point for a particle.

There are **singular points** across the standing waves which are basically the **focal points** also can be treated as **stable equilibrium points**. There are 4-types of singular points that could be caused by these acoustic pressure waves:

**Table 2:** Types of Singular points and their properties.

| Singular Points | Motion              | Stability | Approach                 |
|-----------------|---------------------|-----------|--------------------------|
| Vortex          | Oscillatory         | Stable    | none                     |
| Saddle          | Aperiodic           | Unstable  | Asymptotic               |
| Focal           | Damped Oscillations | Stable    | Using defined directions |
| Nodal           | Aperiodic           | Stable    | Using defined directions |

It is observed that **Vortex** and **nodal** types of singular points are found which explains the rotational motion of the objects levitating in order to conserve the net forces and without any rotational rest levitation due to the **nodal points** in the standing sound-wave pressures respectively.

## 4.2. Operation of Circuit

Upload the code to generate the signal with defined frequency into arduino(ATMEGA328P) chip to connect all the connections as shown in the circuit diagram. Turn on the 12V DC supply unit and then you should be able to see the H-Bridge light up more brightly with 5V from arduino and 12V from DC supply. This shall provide approximately 6V of power supply to each ultrasonic transducers, which should now be operating at a frequency as defined in the code.

Check for the frequency using an **app** known as **Spectrum** which is freely available on **Google Play Store**. The app allows us to read and check the frequency being generated by each of the transducers. since the frequency is above 20KHz, above the audible frequency for humans, the sound made by these transducers is not audible.

Now, if both the transducers are producing pressure waves of approximately the same frequency, they will form standing waves as explained in theory, and an object of low density can be levitated at one of the

nodal or vortex points in between the transducers as shown.

## 5. Software and Program

In this project, Arduino UNO is used, hence it has its own **IDE** for configuring the program in the chip. The program that I have used, directly fuses with the ports as explained before.

The following is the code used:

```
byte TP = 0b10101010; // Every other port
                      // receives the inverted signal

void setup() {
  DDRC = 0b11111111; // Set all analog ports to
                    // be outputs

  // Initialize Timer1
  noInterrupts(); // Disable interrupts

  TCCR1A = 0;
  TCCR1B = 0;
  TCNT1 = 0;
  OCR1A = 200; // Set compare register (16MHz /
              // 200 = 80kHz square wave -> 40kHz full wave)

  TCCR1B |= (1 << WGM12); // CTC mode
  TCCR1B |= (1 << CS10); // Set prescaler to 1
                ==> no prescaling
  TIMSK1 |= (1 << OCIE1A); // Enable compare
                          // timer interrupt

  interrupts(); // Enable interrupts
}

ISR(TIMER1_COMPA_vect) {
  PORTC = TP; // Send the value of TP to the
              // outputs
  TP = ~TP; // Invert TP for the next run
}

void loop() {
  // No loop, most of it is done by the H-Bridge
  // by constant power and signal supplies.
}
```

## 6. Results and Future Scope

### 6.1. Results from Observations

1. The frequency of the first transducer produced is approximately 21.46KHz and the other fluctuates between the range of (19-20)KHz respectively. This is due to the fluctuations caused by the power supply voltage.
2. The approximate distance between the two transducers for them to form standing waves is found

out to be  $(1.7 \pm 0.2)$  centimetres.

Calculation of distance between the transducer to produce standing waves:

$$d = \frac{n\lambda}{2} \quad (15)$$

Wavelength can be calculated from the frequency recorded, from the transducers, by the relation:

$$f = \frac{c_s}{\lambda} \quad (16)$$

$$\lambda = \frac{c_s}{f} \quad (17)$$

here, speed of sound in air medium is  $c_s = 343$  *mt/s*.

For the arrangement made the approximate values are  $n = 10$ , hence,  $d = 1.5 \pm 0.2$ .

3. There exist few vortex singular points which make the objects rotate along the direction of pressure-waves, and the rest are nodal points which do not rotate the object due to the reasons specified in theory.

## 6.2. Future Scope

Levitation is a promising method for container-less processing of microchips and other small, delicate objects in industry. Container-less processing may also be used for applications requiring very-high-purity materials or chemical reactions too rigorous to happen in a container.

There is also interest in using levitation to suspend protein droplets for use of X-ray diffraction imaging without containers, which attenuate the beam and reduce the quality of the diffraction data provided.

Acoustic levitation has also been proposed as a technique for creating a volumetric display, with light projected onto a particle, which moves along the path to create the image faster than the eye can process.

Further developments in the project can be used in 3d-printing objects by levitation, which enable a  $360^\circ$  spatial configuration for better accuracy.

## 7. Acknowledgement

I would like to express my special thanks of gratitude to my professor Dr. Vineeth Valsan who gave me the golden opportunity to do this wonderful project. Secondly I would also like to thank my parents and friends who helped me a lot in finalizing this project within the limited time frame.

## 8. References:

1. Freedman, R. A., Young, H. D. (2019). University Physics with Modern Physics (4th ed.). Pearson.
2. Prakash, S. (n.d.). (2012). Mathematical Physics with Classical Mechanics (2nd ed.). Sultan Chand Sons.
3. Mini Acoustic Levitation. (2018, November 26). <https://create.arduino.cc/projecthub/millerman4487/mini-acoustic-levitation-30177e>
4. Tripathi, P., Kumar, S.A., Choubey, A., Senthilmurugan, S. (2018). Aural Beam Levitation Using the Concept of Acoustics. (n.d.). International Journal of Research and Scientific Innovation (IJRSI), V(IV). <https://www.rsisinternational.org/journals/ijrsi/digital-library/volume-5-issue-4/105-108.pdf>
5. Arduino. (n.d.). Port manipulation. Port Registers. <https://www.arduino.cc/en/Reference/PortManipulation>. [Accessed : 25-May-2021]
6. ESP32 with DC Motor - Control Speed and Direction — Random Nerd Tutorials, Randomnerdtutorials.com, 2021. [Online]. Available: <https://bit.ly/3vm6Zqr>. [Accessed: 25- May- 2021]