

M-3: Emergence of “Strong Interaction”

Naohiro Ozawa

Mailing address:

Naohiro Ozawa

**1-8-27, Sakuraoka, Tyuuou-ku, Saitama City, Saitama-kenn, Japan
338-0005**

Tel: +81-048-854-4111

Fax: +81-048-854-4111

Email: 1148ldfp@jcom.home.ne.jp

Short title: Emergence of Strong Interaction

Key words:

“Strong interaction”

Quarks/anti-quarks (u , \bar{u} , d , \bar{d})

Nuclear group (p , \bar{p} , n , \bar{n})

π -on group (π^+ , π^- , π^\pm , π^0)

Gluons

Neutrinos

PACS Classification numbers:

12.38.-t Quarks, gluons, and QCD

12.40.-y Other models for strong interactions

13.15.+g Neutrino interactions

14.20.Dh Protons and neutrinos

Abstract

The conclusion of this paper is that the “strong interaction” that emerged as the universe developed through the mediation of two pairs of four types of neutrinos (ν_μ , $\bar{\nu}_\mu$, ν_e , $\bar{\nu}_e$) acted on two pairs of four types of quarks/anti-quarks (\mathbf{u} , $\bar{\mathbf{u}}$, \mathbf{d} , $\bar{\mathbf{d}}$) to form two particle groups each having an electrical charge composition of (+1, -1, 0, 0) [the π -on group (π^+ , π^- , π^\pm , π^0) and the nucleon group (\mathbf{p} , $\bar{\mathbf{p}}$, \mathbf{n} , $\bar{\mathbf{n}}$)], which became the constituent materials for 120 types of atomic nuclei/anti-atomic nuclei. That is, the emergence of “strong interaction” is the physical force that shouldered the central role within the causal chain that was the development of the universe: from neutrino and quark/anti-quark \rightarrow nucleon/anti-nucleon \rightarrow electron/positron, atomic nuclei/anti-atomic nuclei \rightarrow elements/anti-elements and so on.

The quark chromodynamics on “strong interaction” of the Standard Model however accounts for the emergence of “strong interaction” as basically the result of the union of three colors/anti-colors of quarks/anti-quarks and is, therefore, no more than the result of a random accident. Hence, the principle of “strong interaction” according to the Standard Model is not a causal property that emerged in line with the flow of the development of the universe. For that reason, it is not possible for this principle to organize and connect the past, the present, and the future in a sophisticated manner.

Introduction

The “strong interaction” theory of the Standard Model consists in principle of the union of the three colors of quarks, red, green and blue to produce white color [1,2].

“When three colors align, the result is white color” is something that can be categorized as accidental. Further, since causality must result from the interaction between two entities, this alignment cannot be causal in principle. Accordingly, should it happen that “white color results from when three quarks of three colors align”, or if “three colors align” and three quarks are actually observed to unite, then the real principle behind the union should not be thought of as resulting from “union of three colors” but should be attributed to a different principle. Still, there is no way that the principle of “strong interaction” mediated by gluons has succeeded in accounting for atomic nuclei formation of a highly organized structure in the sequential order 2-8-8-18-18-32-32-2 from proton and neutron pairs. It must be believed that the principle of “strong interaction” mediated by gluons, the origins and components of which have not yet been made clear, must be treated as something separate from the development of the universe, which has consistently been linked as a causal chain.

This paper shows clearly that the formation of all phenomena that later emerged in the universe was brought about through the workings firstly of the “emergence force of the universe” [3] and the “formation force of quarks” [4]. That is, particles consisted only of two pairs of four types of neutrinos ($\nu_\mu, \bar{\nu}_\mu, \nu_e, \bar{\nu}_e$) and quarks (u, \bar{u}, d, \bar{d}) and space consisted of pre-space-time and space-time [3,4]. All later physical phenomena in the universe were formed from these two pairs of four types of neutrinos and quarks. “Strong interaction” operated under these conditions. Moreover, it was inevitable that “strong interaction” would form the two particle groups (the π -on group and the nucleon group) that are capable of forming consistently all the

highly precise structures of more than a hundred types of atomic nuclei/anti-atomic nuclei. Furthermore, although this has not been considered by the Standard Model at all, since “strong interaction” is one aspect of causality, it shouldered the mission of taking over all that resulted from the previous workings of the “formation force of quarks” and passing on the baton to “weak interaction.”

1. The Principle of “Strong Interaction”

At the same time as the universe emerged, the four entities (time, space, energy and heat) contained in the singularity were transformed by way of their mutual causality into the four entities (positive time, negative time, positive space and negative space) that were not space-time or particles as yet [3]. Moreover, the four entities, “positive time, negative time, positive space and negative space”, formed pre-space-time and two pairs of four types of neutrinos ($\nu_\mu, \bar{\nu}_\mu, \nu_e, \bar{\nu}_e$) from 1/4 each of the entire constituent entities of the universe through and formed space-time/anti-space time and quarks/anti-quarks ($\mathbf{u}, \bar{\mathbf{u}}, \mathbf{d}, \bar{\mathbf{d}}$) from the remaining one half through mutual causality at work between these four entities. At this point in time, in order for the universe to develop to its current limitless scale, the two particle groups [the π -on group ($\pi^+, \pi^-, \pi^\pm, \pi^0$) and the nucleon group ($\mathbf{p}, \bar{\mathbf{p}}, \mathbf{n}, \bar{\mathbf{n}}$)] had to form. In other words, whether right or wrong, it was inevitable that “strong interaction” would need to emerge. However, since quarks/anti-quarks were each formed following the requirements of electrical charges, they cannot by themselves be joined to each other. That is, even if a quark and its corresponding anti-quark face each other, it is not

possible for them to be joined together without “weak interaction,” which will be developed later, acting. Because “weak interaction” had not yet emerged at this point in time, even among the great expanse of the universe, quarks and anti-quarks were able to unite through mediation by neutrinos only.

Neutrinos unite quarks/anti-quarks through the principle of union between positive and negative shapes. When negative shapes of “time” and “space” that make up neutrinos are placed with the positive shapes of “time” and “space” that make up quarks, these shapes join like a key to a keyhole to establish a union. However, an unlimited number of particles can be formed when quarks/anti-quarks are joined at random with neutrinos acting as mediators. Therefore, we examined whether the union of two quarks/anti-quarks is possible or not under the conditions that one neutrino participates in the union for each quark or anti-quark, that the joint must always be both the “time” and “space” components for one quark or anti-quark, and that the bond should be formed both with the “head” and “tail.”

There are ten ways to combine two quarks and anti-quarks (Fig. 1). When two neutrinos are used in all the combinations (with anti- μ -neutrino to mediate the combination of quarks and quarks, electron neutrino and anti-electron neutrino to mediate the combination of quarks and anti-quarks, and μ -neutrino to mediate the combination of anti-quark and anti-quark), combinations are made possible at one location each on “time” and “space” and at the “head” and the “tail” of the respective quarks and anti-quarks (Fig. 1). It is clear from the above that, in regard to their types and structures, there is perfect correspondence between neutrinos and quarks. In other words, all combinations of two quarks/anti-quarks are joined by two pairs of four

types of neutrinos (ν_μ , $\bar{\nu}_\mu$, ν_e , $\bar{\nu}_e$). Hence, the theory of “strong interaction” can be defined then as the union of quark and anti-quark by the insertion of the neutrino of the opposite shape to mediate the union of plus and minus shapes of quarks and anti-quarks.

2. Case of Two Combinations of Quarks and Anti-Quarks through “Strong Interaction”

Since the universe started off from zero phenomenon, to form four types of phenomena, space-time (pre-space-time / space-time) and precursor particles (neutrinos and quarks), then, when all four phenomena merge, all phenomena are annihilated [3,4]. The universe, in whatever stage, developed such that when all entities that exist at that point merge, all phenomena would be annihilated with electrical charges and shapes becoming zero. In the formation of elements/anti-elements, electrons/positrons and atomic nuclei/anti-atomic nuclei are needed. The electrical charges of atomic nuclei are positive integral numbers while the electrical charges of electrons are -1 (the electrical charges of anti-atomic nuclei and positrons are the opposites of the charges of atomic nuclei and electrons). Hence, when all elements and all anti-elements are merged, the electrical charges and shapes also become zero. Consequently, quarks and anti-quarks whose electrical charges that are fractional numbers cannot by themselves become direct component materials of atomic nuclei/anti-atomic nuclei. As such, it is necessary that a group of particles/antiparticles having electrical charges of (+1, -1, 0, 0) be formed that would

serve as a bridge between quarks/anti-quarks and atomic nuclei/anti-atomic nuclei. No physical force emerged to satisfy this need other than “strong interaction”. Our research determined whether the group of particles should exist such that electrical charges and shapes become zero through “strong interaction” when all particles/anti-particles of the same group merge and, further, such that the ratio of the constituent materials “time” and “space” should be 5:4 [4]. The third working of the “formation force of quarks” is what made the adjustments so that the electrical charge composition and the ratio of “time” to “space” would be as shown above. If we consider that the third workings of both the “fundamental development force of the universe” and the “emergence force of the universe” separated the four entities starting with “time” into “positive time,” “negative time,” “positive space,” and “negative space” and further separated the four entities starting with “positive time” into “static” and “dynamic” entities, we can see the importance of the third workings of these physical forces.

This section verifies whether there are such particles/anti-particles that form from the union between two quarks and anti-quarks. There are ten ways to combine two quarks and anti-quarks (Fig. 1). Of these ten combinations, the six combinations of $u\bar{d}$, $\bar{u}\bar{d}$, uu , dd , $\bar{u}\bar{u}$, $\bar{d}\bar{d}$ all have total electrical charges that are fractional when the charges of the two quarks/anti-quarks are summed up and therefore cannot form particles/anti-particles. On the other hand, the combinations $u\bar{d}$, $\bar{d}\bar{u}$, $u\bar{u}$ and $\bar{d}\bar{d}$ have electrical charges (+1, -1, 0, 0) form two pairs of four types of particles that satisfy the electrical charge requirements. The same four combinations are joined through the positive and negative shapes of “time” and “space” for a quark and

anti-quark at one location each. More, it was verified that there are two each of the quarks that participate in the formation of these four types of particles, \mathbf{u} , \mathbf{d} , $\bar{\mathbf{u}}$ and $\bar{\mathbf{d}}$ quarks. Accordingly, the positive and negative charges as well as shapes of all particles in this particles group sum up to zero. Even more, it was verified that the composition ratio of “time” and “space” for both quarks (\mathbf{u} and \mathbf{d}) and anti-quarks ($\bar{\mathbf{u}}$ and $\bar{\mathbf{d}}$) is 5:4 (Fig. 2 – bottom). The formation of four combinations of two quarks and two anti-quarks $\mathbf{u}\bar{\mathbf{d}}$, $\mathbf{d}\bar{\mathbf{u}}$, $\mathbf{u}\bar{\mathbf{u}}$, $\mathbf{d}\bar{\mathbf{d}}$ is thus verified as described above. The names for each of these combinations are, from left to right, π^+ , π^- , π^\pm and π^0 (Fig. 2 – top).

The above is STEP 1- first half of the workings of “strong interaction.” Since the motive power of the “emergence force of the universe” is driven by “energy” and “heat,” while the motive power of the “formation force of quarks” is driven by “energy” and “heat” in the four entities “positive time, negative time, positive space, and negative space” [3,4], the motive power of “strong interaction” must be the “energy” and “heat” of the four neutrinos. Accordingly, “Strong interaction – STEP 1” is mediated by electron neutrinos and anti-electron neutrinos (whose “energy” and “heat” are the motive power of this interaction) and acts on the two pairs of the four types of quarks and anti-quarks as the objects. The new phenomena resulting from this STEP is the π -on group $[(\pi^+, \pi^-), (\pi^\pm, \pi^0)]$, which consists of two pairs.

3. Combinations of Three Quarks and Three Anti-Quarks

Each of the two pairs of four types of neutrinos (ν_μ , $\bar{\nu}_\mu$, ν_e , $\bar{\nu}_e$) and quarks (\mathbf{u} ,

\bar{u} , d , \bar{d}) emerged as they corresponded well in all ways. Hence, in the formation of particles/anti-particles during the stage of “strong interaction” STEP 1, it is necessary that the number of precursor particles should be almost the same. However, as shown in the previous section, of the two pairs of particles groups formed during the “strong interaction”, a pair of π -on group (π^+ , π^- , π^\pm , π^0) is already formed only from electron neutrinos and anti-electron neutrinos. Accordingly, it is necessary that later formation should form the other particles group of quarks only and anti-quarks only mediated by μ neutrinos and anti- μ neutrinos. This section verifies whether particles/anti-particles are formed from three quarks only and three anti-quarks only that satisfies the principle of the universe. There are eight combinations of three quarks only and three anti-quarks only as shown in Fig. 3. There are two groups of particles that satisfy the requirement that the sum of electrical charges and of shapes should be zero for two pairs of particles: ($\bar{d} \bar{d} \bar{d}$, $d d d$, $u d d$, $\bar{u} \bar{d} \bar{d}$) and ($u d$, $\bar{u} \bar{u} \bar{d}$, $u d d$, $\bar{u} \bar{d} \bar{d}$). However, only the latter group has the same number of four types of component quarks/anti-quarks (3, 3, 3, 3) and an electrical charge composition of (+1, -1, 0, 0). Hence, a verification is given below to see whether the group of ($u d$, $\bar{u} \bar{u} \bar{d}$, $u d d$, $\bar{u} \bar{d} \bar{d}$) that has three each of component quarks/anti-quarks is formed by the action of “strong interaction” mediated by μ -neutrinos and anti- μ neutrinos.

All particles and anti-particles are joined at one location each of “tails” and “heads” by “strong interaction” mediated by three μ -neutrinos and three anti- μ neutrinos, and further, the ratio of the total amounts of components “time” and “space” of both two particles and two anti-particles is 5:4 (Fig. 3). Hence, it is shown that the

combinations of three quarks and three anti-quarks are formed without any problem at all. The names for the above mentioned two pairs of four types of particles and antiparticles, which have been previously shown to exist in reality, are uud = proton, $\bar{u}\bar{u}\bar{d}$ = anti-proton, udd = neutron, and $\bar{u}\bar{d}\bar{d}$ = anti-neutron (Fig. 3-bottom).

The above process of forming the nucleons group is the work of the latter half of STEP 2 of “strong interaction.” The “energy” and “heat” of the μ -neutrinos and anti- μ neutrinos serve as motive power with μ -neutrinos and anti- μ neutrinos serving as mediators as “strong interaction” acts on the target two pairs of four types of quarks to form the new phenomena called the nucleons group (p , \bar{p} , n , \bar{n}).

4. Combinations of four or more quarks and four or more anti-quarks

While the complete direct work of “strong interaction”-STEP 2 in the formation of the universe was now described, this does not mean that there is no interest to determine whether the universe need to develop combinations of four or more quarks and four or more anti-quarks. What follows indicates that the question whether particle/anti-particle groups form with regards to the combination of four or more quarks and four or more anti-quarks is verified.

Table 1 shows the number of combinations possible in joining four or more quarks and four or more anti-quarks as well as the electrical charges of each component particle. Firstly, since it is necessary that the particles group directly formed from quarks/anti-quarks be the components of atomic nuclei and anti-atomic nuclei bodies,

then it is necessary that these particles be formed from quarks only or from anti-quarks only. Of these, combinations of four, five and seven **u** quarks and **d** quarks are shown in Fig. 4. There are five, six, and eight combinations respectively for four, five and seven quarks. The electrical charges of these combinations are all fractional numbers. Quark combinations other than multiples of three, say 8, 10, 11, 13, 14, and so on, result to particles formed with electrical charges that are fractional numbers (Table 1). Since particles to be formed require that the electrical charges be at least either +1, -1 or 0, all combinations do not qualify. For combinations of multiples of three quarks, starting from 6 (6, 9, 12, 15 and so on), the electrical charges of the combinations with the respective number of **u** quarks (3 (**d** = 3), 4 (**d** = 5), 5 (**d** = 7), 6 (**d** = 9)) are all 1, while with respective number of **u** quarks (2 (**d** = 4), 3 (**d** = 6), 4 (**d** = 8), 5 (**d** = 10)) are all zero (Table 1). However, with regards to combinations when the number of quarks are 6 and 9 in the multiples of 3 quarks combinations, although the resulting electrical charges formed pass the requirement, the composition ratio of “time” and “space” of the component quarks/anti-quarks do not result to 5:4. That is, the composition ratio for 6 quarks is (30 : 26) while that for 9 quarks is (43 : 40). As the number of quarks increases to 12 and 15, the ratio of “space” is getting larger in the composition ratio of “time” and “space.” Consequently, there is not a single combination that qualifies in two pairs of four types of combinations of four or more quarks and four or more anti-quarks.

Discussion

The principle of “strong interaction” as presented in the Standard Model expressed

as “When three quark colors align, white color results” is nothing more than a phenomenological theory that describes phenomenological change. More, the statement “They combine because they become white” is nothing but an afterthought that has no motive power. That being said, although no problems arise if the 8-level structure of atomic nuclei/anti-nuclei of 2-8-8-18-18-32-32-2 pairs formed from proton-neutron pairs result from the workings of “strong interaction” mediated by gluons and “weak interaction” mediated by weak bosons, even the formation of the most simple helium atomic nucleus is not formed successfully from this principle.

This series of papers clearly shows that prior to “strong interaction” becoming operational, only two pairs of four types of neutrinos ($\nu_\mu, \bar{\nu}_\mu, \nu_e, \bar{\nu}_e$) and quarks/anti-quarks ($\mathbf{u}, \bar{\mathbf{u}}, \mathbf{d}, \bar{\mathbf{d}}$) existed. As such, this series of papers shows that it is possible to form all possible combinations of two quarks and two anti-quarks through the principle of bonding between positive and negative shapes between neutrinos and quarks/anti-quarks. More, this series also show that since the universe emerged from zero state, all particles groups that emerge have electrical charges and shapes that sum up to zero and that the composition ratio of “time” and “space” is 5:4. Countless numbers of particles/antiparticles will emerge when formation proceeds without any restriction according to the principle of bonding between positive and negative shapes of neutrinos and quarks/anti-quarks. However, by performing adjustments to fulfill the conditions given above as the third working of the “formation force of quarks,” the result when “strong interaction” mediated by neutrinos is operative is that only the π -on group ($\pi^+, \pi^-, \pi^\pm, \pi^0$) and nucleon group ($\mathbf{p}, \bar{\mathbf{p}}, \mathbf{n}, \bar{\mathbf{n}}$), which are two pairs of four types, are formed.

Since all of the two pairs of four types of neutrinos ($\nu_\mu, \bar{\nu}_\mu, \nu_e, \bar{\nu}_e$) and quarks/anti-quarks ($\mathbf{u}, \bar{\mathbf{u}}, \mathbf{d}, \bar{\mathbf{d}}$) that existed initially were incorporated in the two pairs of four types of π -on group ($\pi^+, \pi^-, \pi^\pm, \pi^0$) and nucleon group ($\mathbf{p}, \bar{\mathbf{p}}, \mathbf{n}, \bar{\mathbf{n}}$), during the stage at which the working of “strong interaction” was operative, the only particles that existed in the entire universe were those of the π -on group and nucleon group. Hence, all mesons, particle/antiparticles, electromagnetic waves, and the 120 types of atomic nuclei/anti-atomic nuclei found in the 8-level structure of 2-8-8-18-18-32-32-2 proton – neutron pairs that that will later emerge in the universe, without exception, are formed only from particles in the π -on group or from particles in the π -on group and nucleon group as constituent materials. That no problem arises from this assertion will be verified in the twenty or more papers that will to be presented later.

Acknowledgments

We would like to take this opportunity to express our deep appreciation for the expert assistance of Mr. Kōichirō Tanibe in creating the final illustrations, performing the text layout, and in doing various other tasks.

References

- [1] B. Povh, K. Rith, C. Scholz, F. Zetsche. *Teilchen und Kerne*. 89—
99. Springer-Verlag Tokyo (1997) .

- [2] Barnett, R.M. *The charm of strange quarks*.47~74 Springer-Verlag Tokyo (2005).
- [3] Ozawa,N, **M-1**: The Universe that Emerged and Developed in a Causal Manner [submitted to].
- [4] Ozawa,N,**M-2**:The Emergence of Quarks and Anti-Quarks [submitted to].

Table 1: Electrical charges of particles for four or more quarks

The rows show the number of component quarks (**u+d**) of particles. The columns show the number of only **u** quarks. All are fractional numbers and integers more than ± 2 except for those that are marked off with rectangles.

Figure Legend

Fig. 1: Combinations of quarks and anti-quarks mediated by neutrinos

For the ten ways by which two quarks and two anti-quarks combine, all the two pairs of four types of neutrinos ($\nu_\mu, \bar{\nu}_\mu, \nu_e, \bar{\nu}_e$) unite according to the principle of bonding between positive and negative shapes.

Fig. 2: Particle groups formed when two quarks and two anti-quarks combine

The electrical charge composition of π -on group ($u\bar{d}, d\bar{u}, u\bar{u}, d\bar{d}$) is (+1, -1, 0, 0) and adding the shapes of the entire group results to zero. Further, the composition ratio of “time” and “space” is 5:4.

Fig. 3: Particle groups formed when three quarks and three anti-quarks combine









When three quarks and three anti-quarks combine, the resulting electrical charges

are (+1, -1, 0, 0). Further, the combination when component quark and anti-quark numbers are the same consist only of two pairs of four types of groups ($u u d$, $\bar{u} \bar{u} \bar{d}$, $u d d$, $\bar{u} \bar{d} \bar{d}$). All are joined without creating problems through “strong interaction” mediated by μ -neutrinos and anti- μ neutrinos. More, the composition ratio of “time” and “space” is 5:4.

Fig. 4: Electrical charge of combinations of four, five and seven quarks

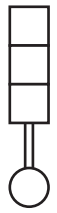
The electrical charges of combinations for four, five and seven quarks are all fractional.

Fig. 1

	Neutrinos				Quarks			
	ν_μ	$\bar{\nu}_\mu$	$\bar{\nu}_e$	ν_e	u	d	\bar{u}	\bar{d}
Materials								
Electric Charge	0	0	0	0	$+2/3$	$-1/3$	$-2/3$	$+1/3$

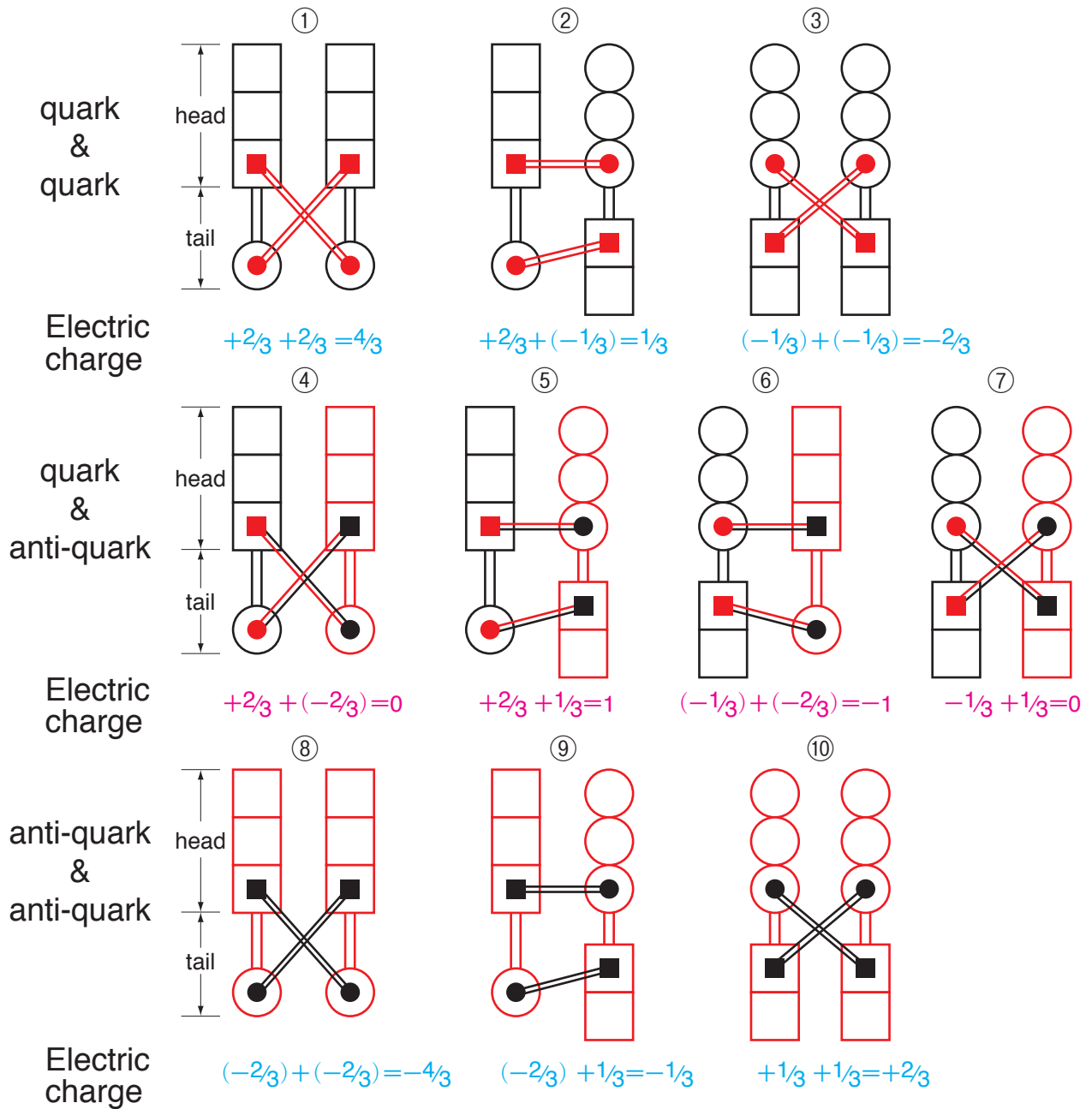
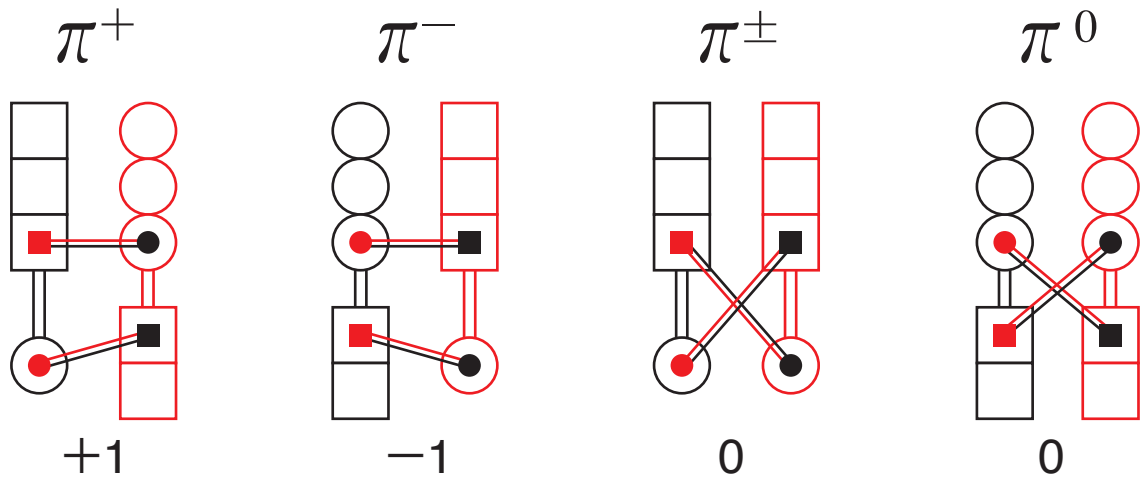
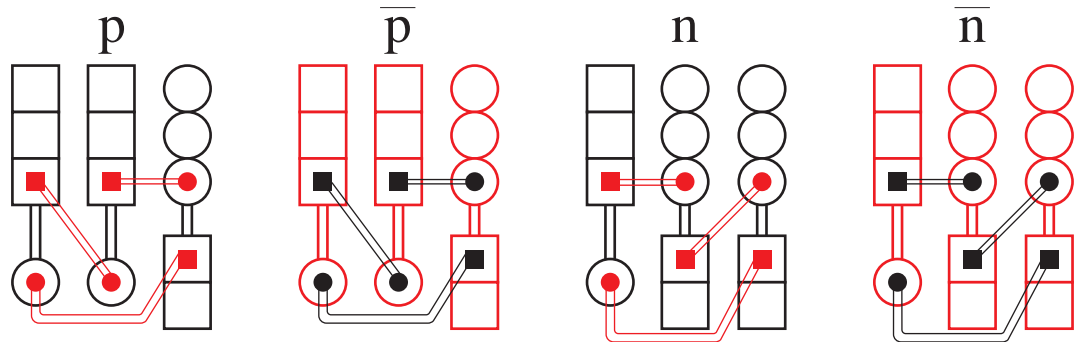
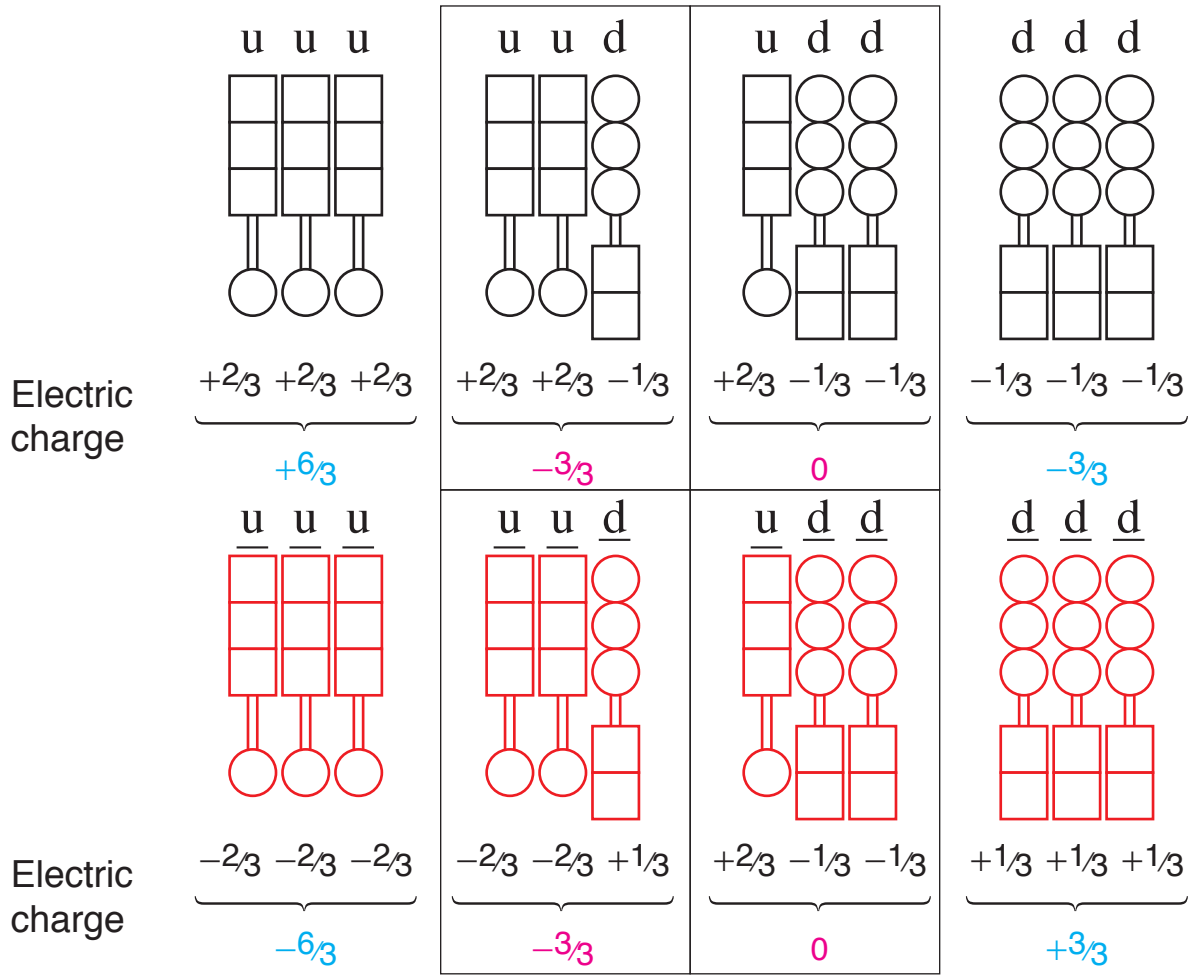

Fig. 2



Quarks	Static-time		Static-space	
u quark ×2	3	6	1	2
d quark ×2	2	4	3	6
	5	10	4	8
Anti-time				
\bar{u} quark ×2	3	6	1	2
\bar{d} quark ×2	2	4	3	6
	5	10	4	8

Fig. 3



		p	n		\bar{p}	\bar{n}		
Ratio of "time" to "space"	Static time	8	7 =	15 : 5	Anti-time	8	7 =	15 : 5
	Static space	5	7 =	12 : 4	Anti-space	5	7 =	12 : 4

Fig. 4

