

# M-4: The Emergence of “Weak Interaction”

Naohiro Ozawa

**Mailing address:**

Naohiro Ozawa

1-8-27, Sakuraoka, Tyuuou-ku, Saitama City, Saitama-kenn, Japan  
338-0005

Tel: +81-048-854-4111

Fax: +81-048-854-4111

Email: [1148ldfp@jcom.home.ne.jp](mailto:1148ldfp@jcom.home.ne.jp)

**Short title: The Emergence of “Weak Interaction”**

**Key words:**

Development of the universe

“Weak interaction”

“Strong interaction”

The nuclear particle group ( $p$ ,  $\bar{p}$ ,  $n$ ,  $\bar{n}$ )

The  $\pi$ -on group ( $\pi^+$ ,  $\pi^-$ ,  $\pi^\pm$ ,  $\pi^0$ )

**PACS Classification numbers:**

06.20.Jr Determination of fundamental constants

13.25.cq Decays of pi mesons

13.38 Be Decays of W bosons

23.40.Bw. Weak interaction

28.20.-v Neutron physics

## Abstract

The view of the Standard Model on the  $\beta$  decay of neutrons through “weak interaction” is that neutrons break down to form protons ( $\mathbf{p}$ ) and weak bosons ( $W^-$ ) and finally into protons, electron and anti-electron neutrinos. The three quarks ( $\mathbf{u}$ ,  $\mathbf{d}$ ,  $\mathbf{d}$ ) that compose neutrons are joined by “strong interaction,” so bonds formed by “strong interaction” supposedly cannot be broken by “weak interaction,” which is far weaker than “strong interaction.” Nevertheless, neutrons do decay. Further, the three quarks ( $\mathbf{u}$ ,  $\mathbf{d}$ ,  $\mathbf{d}$ ) that form neutrons are fundamental particles, and it should not be possible for other fundamental particles to emerge from these three fundamental particles. Nevertheless, not only does ( $\mathbf{u}$ ,  $\mathbf{d}$ ,  $\mathbf{d}$ ) change into ( $\mathbf{u}$ ,  $\mathbf{u}$ ,  $\mathbf{d}$ ), but electrons and anti-electron-neutrinos, which are fundamental particles, also emerge. This must not have a double meaning. As shown here, there are multiple contradictions in “weak interaction” of the Standard Model.

In this paper, “weak interaction” is mediated by the  $\pi$ -ons group that results from the working of “strong interaction” STEP 1 that was described in a previous paper and acts on the nucleons group ( $\mathbf{p}$ ,  $\bar{\mathbf{p}}$ ,  $\mathbf{n}$ ,  $\bar{\mathbf{n}}$ ) that resulted from STEP 2. In other words, at the point immediately prior to the emergence of “weak interaction,” all the particles that existed in the universe were used in order to make “weak interaction” emerge. The “weak interaction” in this paper refers to the “strong interaction” bonds composed of neutrons and  $\pi^\pm$ -ons first being dissolved by “strong interaction.” As such, the reason why neutrons change to protons is just because the  $\mathbf{d}$ -quark of the

neutron is replaced with the  $\bar{u}$ -quark of the  $\pi^\pm$ -on.

## Introduction

In the flow of development of the universe, different forces play important roles: that of “strong interaction” is to form the  $\pi$ -ons group ( $\pi^+$ ,  $\pi^-$ ,  $\pi^\pm$ ,  $\pi^0$ ) and the nucleons group ( $\mathbf{p}$ ,  $\bar{\mathbf{p}}$ ,  $\mathbf{n}$ ,  $\bar{\mathbf{n}}$ ) [1], that of “electromagnetic force” is to form the elements/anti-elements as well as composite / anti-composite entities, and that of “gravity” is to keep the heavenly bodies revolving around each other. However, the role in the development of the universe of “weak interaction” which in the view of the Standard Model is mediated by weak boson is not apparent.  $\beta$  decay of neutron in the view of the Standard Model [2] is a reaction that ultimately results to the appearance of protons, electrons and anti-electron neutrinos [ $\mathbf{n} (\mathbf{udd}) \rightarrow \mathbf{p} (\mathbf{uud}) + \mathbf{e}^- + \bar{\nu}_e$ ]. Although electrons emerge from this working of “weak interaction,” the view of the Standard Model is that electrons and protons are both formed from the energy of vacuum. Hence, it does not consider the emergence of electrons to be the direct product of the working of “weak interaction.” In other words, amid the causal and steady development of the universe, the Standard Model does not make clear just what the working of “weak interaction” did nor what mission it fulfilled in order for the next force of the “electromagnetic force” to work smoothly after the previous force of “strong interaction” formed the  $\pi$ -on group and the nucleon group, both of which consist of two pairs.

Also, the Standard Model believes that  $\mathbf{u}$  and  $\mathbf{d}$  quarks are fundamental particles

and cannot contain other fundamental particles within their structures. Notwithstanding this fact, the Standard Model also believes that the weak boson ( $W^-$ ), electrons ( $e^-$ ), and anti-electron neutrinos ( $\bar{\nu}_e$ ), which are fundamental particles, all emerge from neutrons. This repeatedly exposes the mistakes of the Standard Model. Additionally, although the mass of a neutron ( $u, d, d$ ) is  $0.94 \text{ GeV}/c^2$ , the result of the working of “weak interaction” is the emergence of a proton with mass of  $0.938 \text{ GeV}/c^2$  and a weak boson ( $W^-$ ) with mass of  $80.4 \text{ GeV}/c^2$ . This is a major distortion of the law of conservation of mass.

As shown above, the view of the Standard Model with regards to “weak interaction” contains several contradictions. This research shows through a series of papers how everything could be explained consistently by just one principle. That is, the development of the universe follows the flow of causality from “fundamental development force of the universe”  $\rightarrow$  “emergence force of the universe” [3]  $\rightarrow$  “formation force of precursor particles” [4]  $\rightarrow$  “strong interaction”  $\rightarrow$  “weak interaction”  $\rightarrow$  “electromagnetic force”  $\rightarrow$  “gravity.” It will be made clear that the working of “weak interaction” is mediated by the  $\pi$ -ons group ( $\pi^+, \pi^-, \pi^\pm, \pi^0$ ) formed through “strong interaction” and that electrons are formed by “weak interaction” acting upon the nucleons group ( $p, \bar{p}, n, \bar{n}$ ) formed from the same “strong interaction.” In other words, in expanding the scale of the universe from zero to limitless, the first mission that needs to be accomplished is the formation of electrons, which can do nothing but exert “weak interaction,” and having electrons emerge at the necessary point in time.

## 1. The Causal Development of the Universe

Everything in the development of the universe is the result of causality. With only one pair of opposing entities, the development of the universe ends with only one causal result. As such, in order to connect causality, there must be two pairs of mutually opposing entities that give birth to new causal relationships. That is why, it can be said that the development of the universe is, in principle, the causality between two opposing entities. Before examining the working of "weak interaction," we will investigate the process of causality leading to the emergence of "weak interaction" here. Immediately prior to the emergence of the universe, there were two pairs of entities (time, space, energy, and heat) that were causally connected [3] (Fig. 1 – top).

The four entities that existed in the singularity were transformed into two pairs of four types of entities ("positive time," "positive space," "negative time," and "negative space") by way of the fundamental forces possessed by the universe. This was the start of the universe. Next, through the working of the "emergence force of the universe" - STEP 1 and STEP 2, pre-space-time and two pairs of four types of neutrinos ( $\nu_\mu$   $\bar{\nu}_\mu$   $\nu_e$   $\bar{\nu}_e$ ) were formed from 1/4 each of the four entities starting with "positive time," which were the constituent materials of the entire universe. After that, from the working of the "emergence force of the universe" connecting to the "formation force of quarks," the remaining half of the entities ("positive time," "positive space," "negative time," and "negative space") divided into two pairs each of "dynamic" entities and "static entities." In response, the "formation force of quarks" allocated the "energy" and "heat" that were supposed to be allocated to the "dynamic" entities to the "static" entities as electrical charge (Fig. 1 - middle). Hence, from the

working of the "formation force of quarks" STEP 1, two pairs of four types of quarks ( $\mathbf{u}$ ,  $\bar{\mathbf{u}}$ ,  $\mathbf{d}$ ,  $\bar{\mathbf{d}}$ ) were formed using the four "static" entities, and, from the working of the "formation force of quarks" STEP 2, space-time/anti-space-time and black holes were formed from the four "dynamic" entities (Fig. 1 - middle - right). After that, "strong interaction" (STEP 1) mediated by two pairs of four types of neutrinos acted on the same two pairs and four types of quarks to form a group of two pairs of four types of  $\pi$ -ons ( $\pi^+$ ,  $\pi^-$ ,  $\pi^\pm$ ,  $\pi^0$ ), and "strong interaction" (STEP 2) acted to form a group of two pairs of four types of nucleons ( $\mathbf{p}$ ,  $\bar{\mathbf{p}}$ ,  $\mathbf{n}$ ,  $\bar{\mathbf{n}}$ ) (Fig. 1 - bottom).

As shown above, it can be seen that causality was at work between two pairs of four types of entities at any stage of the development of the universe. Further, it can be seen that exactly half each of the constituent materials of the entire universe consisted of space-time and of particles—which were all the same original materials—respectively.

## **2. The principle of “weak interaction” and dissolution of $\pi$ -ons and nucleons**

Immediately before the emergence of “weak interaction” in the development of the universe, the  $\pi$ -ons group ( $\pi^+$ ,  $\pi^-$ ,  $\pi^\pm$ ,  $\pi^0$ ) was already formed through the working of “strong interaction” STEP 1, while the nucleons group ( $\mathbf{p}$ ,  $\bar{\mathbf{p}}$ ,  $\mathbf{n}$ ,  $\bar{\mathbf{n}}$ ) was already formed through STEP 2 of the same “strong interaction.” At this point, it became possible to form electrons, protons, and atomic nuclei as well as anti-atomic nuclei, which are indispensable in the formation of elements/anti-elements and

composite bodies/anti-composite bodies, which is the reason for the emergence of “weak interaction.” Since particles in the nucleons group cannot combine by themselves, union between particles of the nucleons group is accomplished through the mediation of the particles from the  $\pi$ -ons group. In other words, the  $\pi$ -ons group becomes the mediator of “weak interaction,” which acts on the particles of the nucleons group through the union of the positive and negative forms of quarks and anti-quarks. However, with “strong interaction” uniting  $\pi$ -ons group ( $\pi^+$ ,  $\pi^-$ ,  $\pi^\pm$ ,  $\pi^0$ ) and nucleons group ( $p$ ,  $\bar{p}$ ,  $n$ ,  $\bar{n}$ ), “weak interaction” cannot take effect. It becomes necessary at this point then that  $\pi$ -ons and nucleons be dissolved through the working of “strong interaction” to restore the quarks / anti-quarks into their original independent states. This task of dissolving the  $\pi$ -ons and nucleons that are bonded by “strong interaction” cannot be done by “weak interaction” which is very weak compared to “strong interaction”. The only way this can be done is by the action of “strong interaction” which is the strongest force in the universe by pulling out neutrinos from the composite bodies.

This paper, investigates the view of the Standard Model regarding  $\beta$  decay of neutrons through the workings of “weak interaction”. In this paper, the object of this reaction is the formation of electron through the working of “weak interaction” mediated by  $\pi^\pm$ -ons. As described above, before “weak interaction” started to be at work, “strong interaction” dissolved neutrons and  $\pi^\pm$ -ons into their independent states. This is the third force exerted by "strong interaction" so that "weak interaction" acts to connect the "fundamental development force of the universe," the "emergence force of the universe," and the "formation force of precursor particles," which were

the previous forces, to the next force. A neutron is broken down into its independent components: **u**-quark, 2 **d**-quarks, and 3 anti- $\mu$ -neutrinos while a  $\pi^\pm$ -on is broken down into its independent components: **u**-quark, anti-**u**-quark, electron neutrino, and anti-electron neutrino (Fig. 2).

### 3. Formation of electrons through “weak interaction”

In the working of “weak interaction” acting on neutrons and mediated by  $\pi^\pm$ -ons, firstly, the two independent **u**-quarks and one independent **d**-quark are united through “strong interaction” mediated by three anti- $\mu$ -neutrinos to form a proton (Fig. 3 – center). Afterwards, anti-**u**-quark that used to compose a  $\pi^\pm$ -on is bonded with the **d**-quark that used to compose a neutron by joining the positive and negative shapes of the **d**-quark and anti-**u**-quark, that is, by “weak interaction” (a). Since anti-**u**-quark **d**-quark are different quark types, they can only unite partially (3 locations). In order to form particles, quarks and anti-quarks must be united at the “head” and the “tail” by both “strong interaction” and “weak interaction” or by one of “strong interaction” or “weak interaction.” These particles are bonded by “strong interaction” mediated by anti-electron neutrino ( $\bar{\nu}_e$ ) to form an electron (b).

When a quark and anti-quark is joined through “weak interaction”, the “static time” and “static space” that consist **d**-quark and “anti-time” and “anti-space” that consist anti-**u**-quark unite to form a composite entity at three locations with no gaps. Hence, a part of “dynamic time / anti – dynamic time” and of “dynamic space / anti-dynamic space” that fill up “static time”, “static space”, “anti-time” and “anti-space” spreads



out to envelope the surroundings of electrons [4]. The space-time type formed from these four entities is the electromagnetic field. As shown above, this “weak interaction” reaction inevitably forms electromagnetic field. The anti-electron neutrino ( $\bar{\nu}_e$ ) that composed  $\pi^\pm$ -on does not participate, and therefore remains independent as it is. The above describes the working of “weak interaction” STEP 1 to form electrons from  $\pi^\pm$ -ons and neutrons.

#### 4. Interpreting the weak boson ( $W^-$ ) as neutrino and quark

This section compares the working of “weak interaction” as viewed from the Standard Model and from the view of this research in an effort to interpret the weak boson ( $W^-$ ) as a neutrino and a quark/anti-quark. It verifies that “weak interaction” mediated by the weak boson as viewed by the Standard Model is not causal but phenomenal and that the virtual particle weak boson ( $W^-$ ) never existed from the very start. In the view of the Standard Model regarding “weak interaction”, a neutron ( $n$ ) is transformed to a proton and weak boson ( $n \rightarrow p + W^-$ ) with the weak boson ( $W^-$ ) further breaking down into an electron and anti-electron neutrino ( $n \rightarrow p + W^- \rightarrow p + e^- + \bar{\nu}_e$ ) (Fig. 4 – left)

The view of this research with regards to the working of “weak interaction” is that, firstly, the bonds between the neutrinos that compose neutrons and  $\pi^\pm$  - ons are first dissolved so that the component quarks, anti-quarks and neutrinos all revert to being independent. The three quarks that become separated ( $u, u, d$ ) first unite through “strong interaction” mediated by three anti- $\mu$  neutrinos to form a proton. At this

stage (Fig. 4 – c – right), four independent precursor particles ( $\mathbf{u}$ ,  $\mathbf{d}$ ,  $\nu_e$ ,  $\bar{\nu}_e$ ) remain without forming particles except protons. During the next stage (d), an anti- $\mathbf{u}$  quark unite with a  $\mathbf{d}$  quark through “weak interaction” to form composite entity that further unites through “strong interaction” mediated by electron neutrinos ( $\nu_e$ ) to form electrons ( $\mathbf{e}^-$ ). With that, from the composite entity formed from a  $\mathbf{d}$  quark and an anti- $\mathbf{u}$  quark, the “dynamic” entities contained spread out to form an electromagnetic field. The anti-electron neutrino ( $\bar{\nu}_e$ ) that composed  $\pi^\pm$  does not participate in the formation of protons and electrons and therefore remains as is (Fig. 4 – bottom – right).

As shown above, ( $\mathbf{p} + \mathbf{e}^- + \bar{\nu}_e$ ) results from the working of “weak interaction” on a neutron from the views of both the Standard Model and this research. However, the beginning and the interim stages are different. It is impossible for ( $\mathbf{p} + \mathbf{e}^- + \bar{\nu}_e$ ) to result from ( $\mathbf{udd} + 3 \times \bar{\nu}_u$ ), which the Standard Model claims to be the precursor particle composition of the neutron. Four precursor particles ( $\mathbf{u}$ ,  $\bar{\mathbf{u}}$ ,  $\nu_e$ ,  $\bar{\nu}_e$ ) are lacking. Since the  $\mathbf{d}$  quark of the neutron and the  $\mathbf{u}$  quark of the proton are interchanged, the prior step ( $\mathbf{p} + \mathbf{W}^-$ ) becomes, as shown in Fig. 4-c, [ $\mathbf{p} + (\mathbf{d}, \bar{\mathbf{u}}, \nu_e, \bar{\nu}_e)$ ]. For that reason, we hypothesize that because quarks and anti-quarks cannot exist independently (yet it can be observed from the results that something does exist), the four independent precursor particles ( $\mathbf{d}, \bar{\mathbf{u}}, \nu_e, \bar{\nu}_e$ ) combine with neutrinos and anti-neutrinos to form the weak boson ( $\mathbf{W}^-$ ). If so, since ( $\mathbf{n} \rightarrow \mathbf{p} + \mathbf{W}^-$ ) that appears in the Standard Model is substantially a contradiction, it can be verified that, besides the neutron ( $\mathbf{n}$ ), four precursor particles that constitute  $\pi^\pm$  ( $\mathbf{u}, \bar{\mathbf{u}}, \nu_e, \bar{\nu}_e$ ) must exist in

Fig. 4-a-left.

## Discussion

Since the “weak interaction” in the view of the Standard Model mediated by the weak boson does not have a working motive force, does not have any connection with “strong interaction” that comes before and “electromagnetic force” that comes later, and has a vague causal relationship with its peripheral factors, it is impossible to place this causality within the flow of development of the universe. In this research, “weak interaction” is connected to “strong interaction” as it works between two pairs of four types of  $\pi$ -ons group and nucleons group, both of which result from “strong interaction”. Moreover, it is connected with “electromagnetic force” as it is responsible for the formation of electrons. The principle of “weak interaction” is the principle of causality between two pairs of four types each of  $\pi$ -ons group ( $\pi^+$ ,  $\pi^-$ ,  $\pi^\pm$ ,  $\pi^0$ ) and of nucleons group ( $\mathbf{p}$ ,  $\bar{\mathbf{p}}$ ,  $\mathbf{n}$ ,  $\bar{\mathbf{n}}$ ). That is, quarks and anti-quarks are united as the composite entity joined through their positive and negative shapes. As such, “weak interaction” cannot work on  $\pi$ -ons and nucleons that are bonded by “strong interaction.” In order for “weak interaction” to take effect, the bond caused by “strong interaction” must be dissolved and the neutrinos and quarks / anti-quarks restored into their independent states. Only then can “weak interaction” start to work.

With the above preconditions, when “weak interaction”, mediated by  $\pi^\pm$  ons works on neutrons, protons, electrons, and anti-electron neutrinos result [ $\mathbf{n}$  ( $\mathbf{udd}$ ) +  $\pi^\pm(\mathbf{u}\bar{\mathbf{u}})\rightarrow\mathbf{p}$  ( $\mathbf{uud}$ ) +  $\mathbf{e}^-(\mathbf{d}\bar{\mathbf{u}})+\bar{\nu}_e$ ]. This working of “weak interaction” as viewed in this research neatly resolves the several contradictions in the working of “weak

interaction” mediated by weak bosons as viewed by the Standard Model.

Firstly, a proton resulted from interchanging the **d** quark of a neutron with the **u** quark of a  $\pi^\pm$ -on. An electron resulted (this is the essential purpose) from the working of “weak interaction” that joined the anti-**u** quark of a  $\pi^\pm$ -on and the **d** quark of a neutron, and then joined further by “strong interaction” through the mediation of the anti-neutrino of the  $\pi^\pm$ -on. At this point, a small electromagnetic field is formed around the electron. In the Standard Model, it is impossible to form an electromagnetic field from the principle of “weak interaction” mediated by weak bosons. Since a neutron (**udd**) is composed of three anti-mu neutrinos [1], nowhere in its structure can an electron neutrino or anti-electron neutrino be found. Notwithstanding this absence, an electron neutrino is used in the formation of an electron. Lastly, independent anti-electron neutrinos result. These are evidences of the fact that  $\pi^\pm$ ons are joined not through a gluon but “strong interaction” mediated by neutrinos.

The fatal contradiction of the Standard Model view of “weak interaction” is that a proton, an electron and an anti-electron neutrino [**p** (**uud** +  $3 \times \bar{\nu}_\mu$ ) + **e**<sup>-</sup>(**d** $\bar{u}$  +  $\nu_e$ ) +  $\bar{\nu}_e$ ] cannot substantially result from the component precursor particles of a neutron which are **n** = (**udd** +  $3 \times \bar{\nu}_\mu$ ). In order for [**p** (**uud** +  $3 \times \bar{\nu}_\mu$ ) + **e**<sup>-</sup>(**d** $\bar{u}$  +  $\nu_e$ ) +  $\bar{\nu}_e$ ] to result, four precursor particles other than the neutron (**u**,  $\bar{u}$ ,  $\nu_e$ ,  $\bar{\nu}_e$ ) are absent. Incidentally, (**u**,  $\bar{u}$ ,  $\nu_e$ ,  $\bar{\nu}_e$ ) is just the component precursor particles of a  $\pi^\pm$ -on. That is, in the  $\beta$  decay of neutrons by “weak interaction” in the view of the Standard Model,  $\pi^\pm$ -ons which are needed to activate “weak interaction” are absent.  $\pi^\pm$ -ons consist of corresponding **u** quarks and anti-**u** quarks which makes it apparently

difficult to conceptualize. If so, then the weak boson ( $W^-$ ) that the Standard Model speaks of becomes composed of the four independent precursor particles ( $d$ ,  $\bar{u}$ ,  $\nu_e$ ,  $\bar{\nu}_e$ ). Quarks and anti-quarks exist independently only for an instant. Hence, we have been able to discern the background behind why the four precursor particles ( $d$ ,  $\bar{u}$ ,  $\nu_e$ ,  $\bar{\nu}_e$ ) have been pigeonholed as virtual particles, which is a concept that is difficult to adapt to.

## Acknowledgments

We would like to take this opportunity to express our deep appreciation for the expert assistance of Mr. Kōichirō Tanibe in creating the final illustrations, performing the text layout, and in doing various other tasks.

## References

- [1] Ozawa, N, **M-3**: Emergence of “strong interaction” [submitted to COMMSPHYSSDY]. .
- [2] B. Povh, K. Rith, C. Scholz, F. Zetsche. *Teilchen und Kerne*. 105—140 Springer-Verlag Tokyo (1997) .
- [3] Ozawa, N, **M-1**: The Universe that Emerged and Developed in a Causal Manner.
- [4] Ozawa, N. **M-2**: The Emergence of Quarks and Anti-Quarks. [submitted to COMMSPHYSSDY]. .

## Figure Legends

### Fig. 1: Causal flow of the development of the universe

The four entities (time, space, energy, and heat) that existed as a singularity underwent four processes involving the causal relationships between two pairs of four entities at each process to become two pairs each of  $\pi$ -ons and nucleons. These preconditions set up the stage for “weak interaction” to start working.

### Fig. 2: Dissolution of “strong interaction” bonds by “strong interaction”

When the “strong interaction” bonds of  $\pi^\pm$ -ons and neutrons are dissolved,  $(\mathbf{u}, \bar{\mathbf{u}}, \nu_e, \bar{\nu}_e)$  and  $(\mathbf{u}, \mathbf{d}, \mathbf{d} + 3 \times \bar{\nu}_\mu)$  result.

### Fig. 3: Weak interaction acts on neutrons and mediated by $\pi^\pm$ -ons

When “strong interaction” bonds of  $\pi^\pm$ -ons and neutrons are dissolved, protons are formed first, followed by the formation of electrons as “strong interaction” act between the  $\mathbf{u}$  quarks of  $\pi^\pm$ -ons and  $\mathbf{d}$  quarks of neutrons, and further united by “strong interaction” mediated by electron neutrinos. An electromagnetic field is formed around electrons. Anti-electron neutrinos do not participate in any particle composition at all and remains independent.

### Fig. 4: Fatal contradiction of “weak interaction” mediated by weak boson

The final result of “weak interaction” mediated by weak bosons acting on neutrons is the appearance of protons, electrons and anti-electron neutrinos. Breaking down each particle into neutrinos and quarks/anti-quarks, the left side of the equation is seen to lack  $\mathbf{u}$  quark, anti- $\mathbf{u}$  quark, electron neutrino, and anti-electron neutrino (the component entities of  $\pi^\pm$ -ons) found on the right side. Comparing the Standard Model and this research on row **c** shows that the weak boson ( $W^-$ ) is composed of

the four independent precursor particles ( $\mathbf{d}$ ,  $\bar{\mathbf{u}}$ ,  $\nu_e$ ,  $\bar{\nu}_e$ ).

# Fig. 1

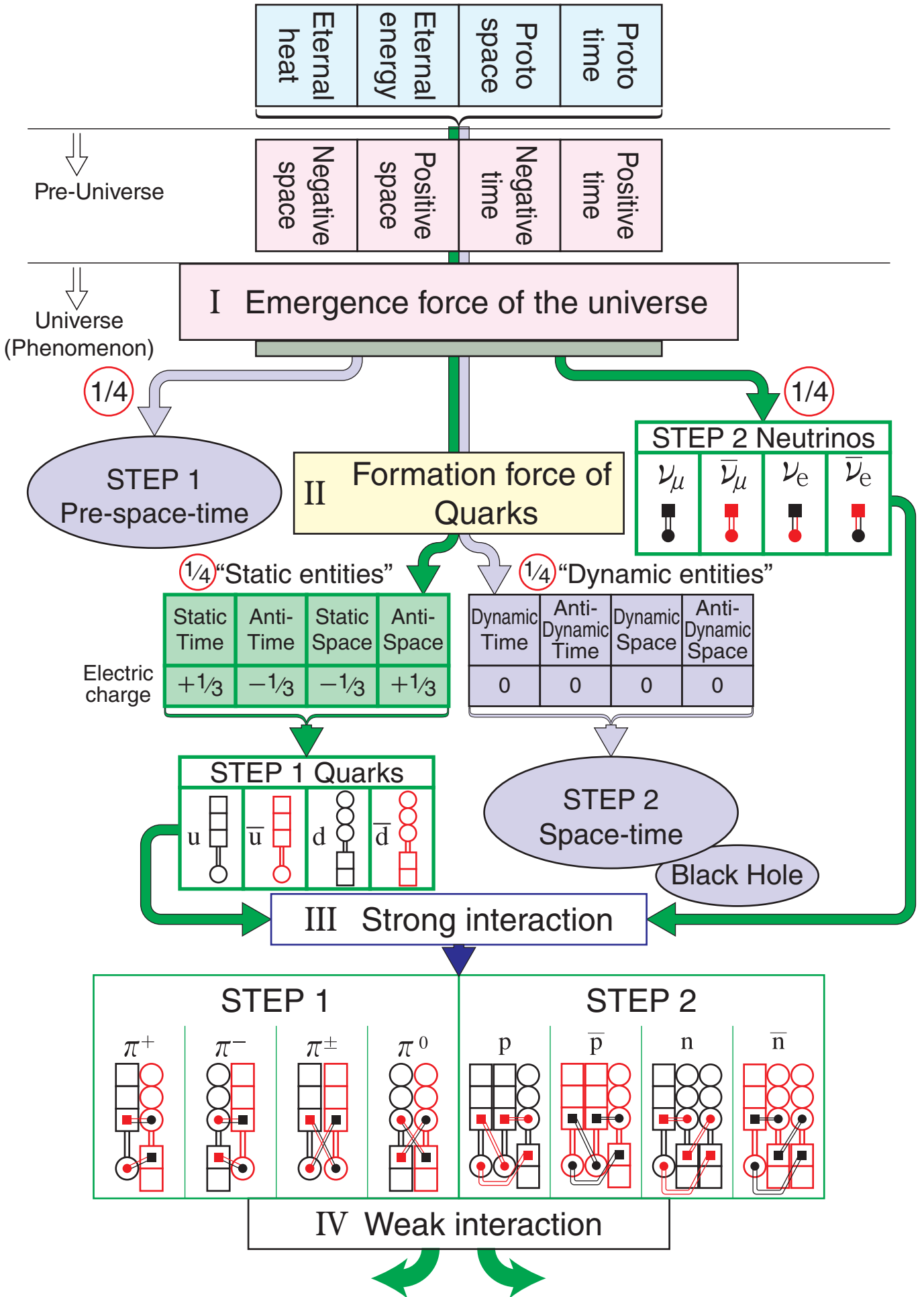



Fig. 2

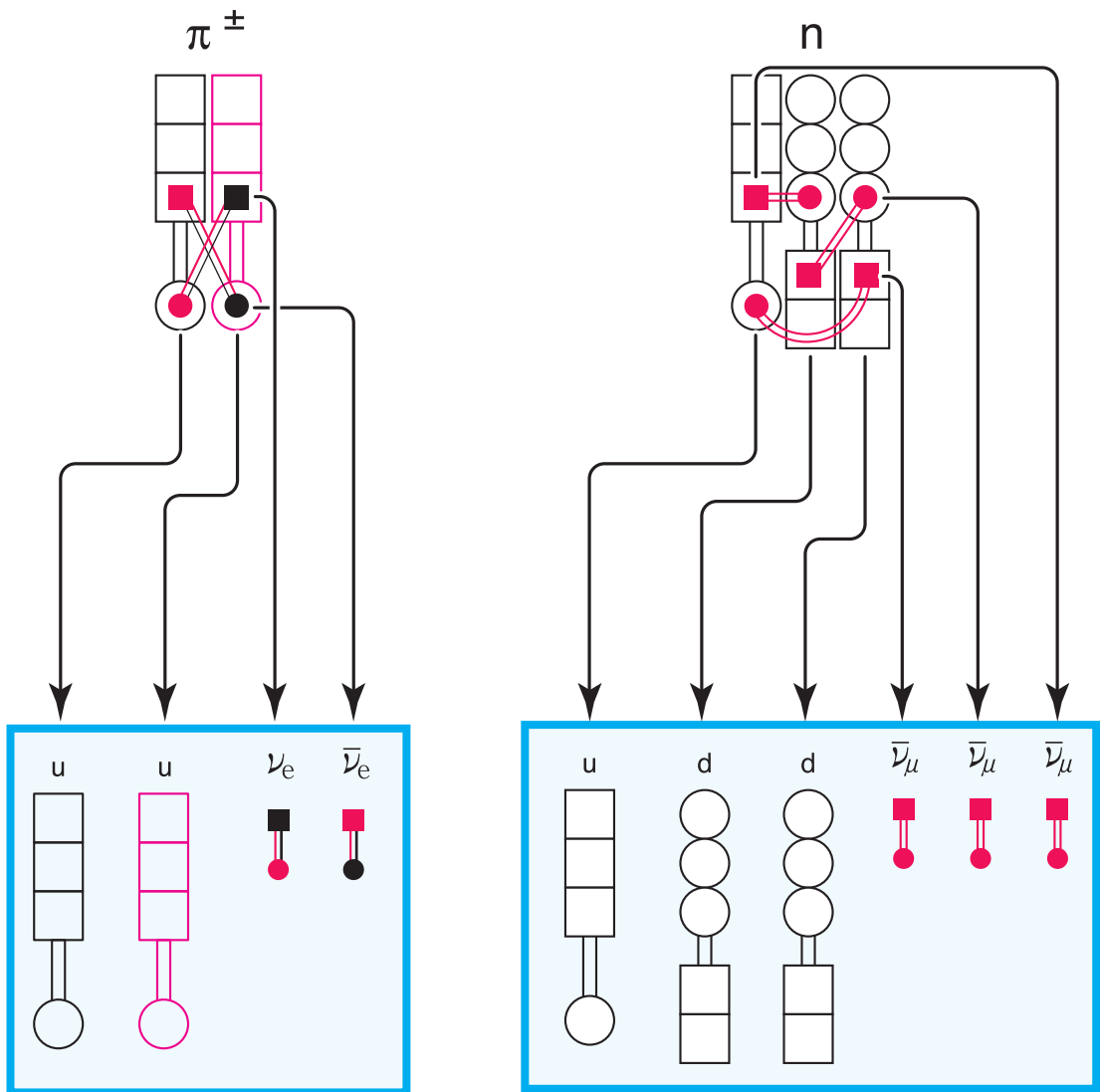

Fig. 3

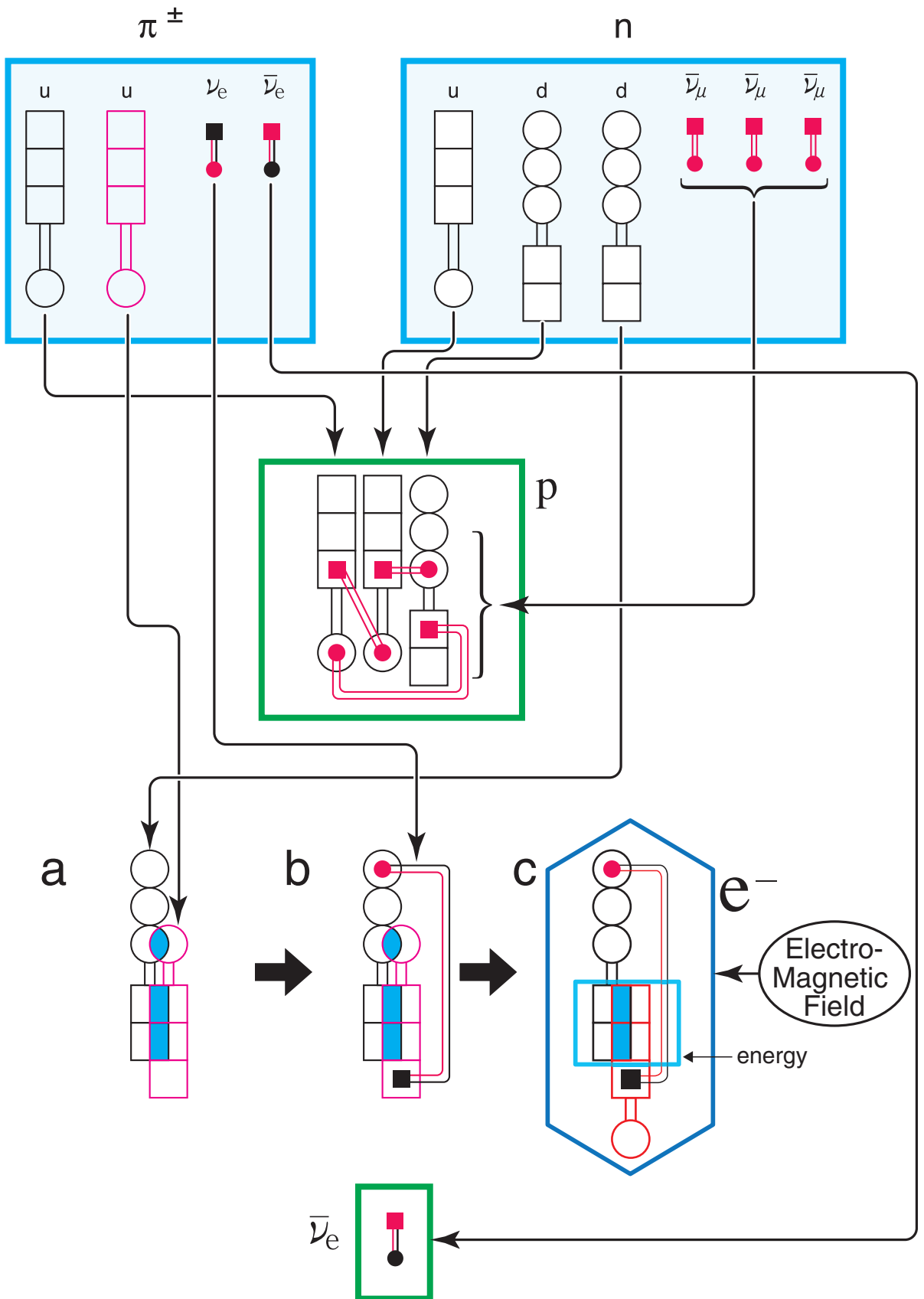

Fig. 4

